

## EC DECLARATION OF CONFORMITY FOR MACHINES

(DIRECTIVE 2006/42/EC)

**Manufacturer:** FAAC S.p.A.

**Address:** Via Benini, 1 - 40069 Zola Predosa BOLOGNA - ITALY

**Declares that:** Operator mod. S450H

is built to be integrated into a machine or to be assembled with other machinery to create a machine under the provisions of Directive 98/37 EC

complies with the essential safety requirements of the following EEC directives:

2006/95/EC Low Voltage Directive

2004/108/EC Electromagnetic Compatibility Directive

It further declares that it is not allowed to put the device in operation until the machine it has to be integrated into or of which it is going to become an integral part has been identified and its conformity has been declared under the provisions of the Directive 2006/42/EEC and subsequent amendments.

Bologna, 01.04.09

The Managing Director  
A. Marcellan



## IMPORTANT INSTRUCTIONS FOR THE INSTALLER GENERAL SAFETY

- 1) **ATTENTION! To ensure personal safety, carefully read following instructions. Improper installation or misuse of the product can cause serious personal injuries.**
- 2) **Carefully read the instructions before installing the product.**
- 3) Packaging material (plastic, polystyrene, etc.) is a potential hazard and must be kept out of reach of children.
- 4) Keep these instructions for future reference.
- 5) This product was designed and manufactured exclusively for the purpose indicated in this documentation. Any other use, not expressly indicated here, could compromise the good condition/operation of the product and/or be a source of danger.
- 6) FAAC declines any responsibility for improper use or use other than that for which the automated system was intended.
- 7) Do not install the equipment in an explosive atmosphere: the presence of inflammable gas or fumes is a serious danger to safety.
- 8) Mechanical constructive elements must comply with the requirements of the EN 12604 and EN 12605 standards.  
In addition to their national legal regulations, countries outside the EC must follow the above mentioned standards in order to guarantee an adequate level of safety.
- 9) FAAC cannot be held responsible for failure to observe technical standards in the construction of the closing elements to be motorised nor for any deformation which may occur during use.
- 10) The installation must be carried out in conformity with the EN 12453 and EN 12445 standards.  
In addition to their national legal regulations, countries outside the EC must follow the above mentioned standards in order to guarantee an adequate level of safety.
- 11) Disconnect the power supply before any operation on the system.
- 12) The power mains of the automated system must be fitted with a multi-pole power switch with a switch-contact gap of at least 3 mm. The use of a 6-A thermomagnetic switch with multi-pole switching is recommended.
- 13) Make sure that a differential switch with trip threshold of 0.03 A is fitted upstream of the system.
- 14) Make sure that the earthing system is at the state of art and connect it to the metallic parts of the closing system.
- 15) The automated system is equipped with an intrinsic anti-crushing safety device of the torque control type. Its tripping threshold must be verified according to the requirements specified in the Standards listed in 10.
- 16) The safety devices (EN 12978) protect from the **hazards caused by mechanical movements**, such as crushing, entrapment and shearing hazards.
- 17) Each installation should be fitted with at least one flashing light (e.g. FAACLIGHT) and a warning sign suitably secured to the frame structure, in addition to the devices described in 16 above.
- 18) FAAC declines any responsibility regarding safety and efficient operation of the automated system if parts other than FAAC original parts are used.
- 19) Use only FAAC original parts for maintenance.
- 20) Do not in any way modify the automated system components.
- 21) The installer shall provide all information concerning the manual operation of the system in the event of an emergency and shall hand over to the end-user the warning instructions supplied with the product.
- 22) Keep children, adults or objects away from the product while it is operating.
- 23) Keep remote controls or other pulse generators out of reach of children, to prevent the automated system from being activated unintentionally.
- 24) Transit is permitted only when the automated system is non in operation.
- 25) The automated system cannot be repaired/adjusted by the end-user; these operations can only be carried out by qualified personnel.
- 26) Maintenance: the functional check of the system must be carried out at least every six months; pay special attention to the good working condition of the release and safety devices (including, where foreseen, the thrust force of the operator).
- 27) Feed the automation system only when explicitly stated.
- 28) **Anything not expressly specified in these instructions is not permitted.**

# S450H

## 1 DESCRIPTION AND TECHNICAL SPECIFICATIONS

The FAAC S450H automated system for swing-leaf gates consists of an electrical pump and an hydraulic piston transmitting the leaf movement, assembled in a single block.

The model with hydraulic lock can automate leaves up to 2 m. It does not require the installation of electric locks and guarantees that the leaf is mechanically locked when the motor is not in operation. The model without hydraulic lock always needs one or more electric locks to guarantee the leaf mechanical lock. **The S450H automated systems have been designed and built to automate swing-leaf gates. Avoid any other use whatever.**

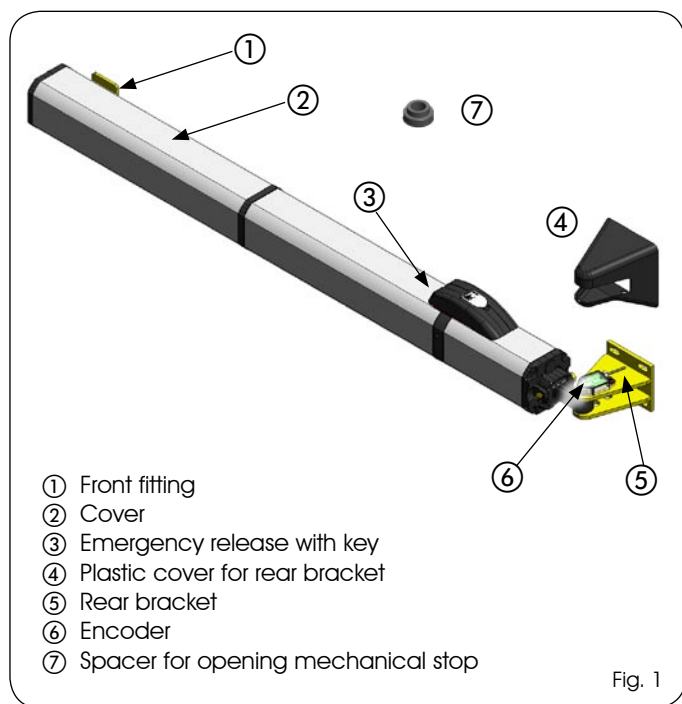

Fig. 1

TECHNICAL SPECIFICATIONS	CBAC OPERATOR	SB OPERATOR
Power supply (V dc)	24 - 36	
Power consumption (W)	70 (nominal) - 288 (maximum)	
Protection class	IP 55	
Oil type	FAAC HP OIL	
Operating temperature	-20°C +50°C	
Rated Operating Time (R.O.T.)	Continuous duty at 55°C	
Hydraulic lock	Installed	Not installed
Traction/thrust force max (N)	5000 (E124) - 3600 (E024S)	
Max. opening angle	See table 1	
Max. leaf length (m)	2	3
Rod linear speed (Cm/s)	2,5 (E124) - 2,0 (E024S)	
Effective rod stroke (mm)	311	
Operator weight (kg)	10,8	

\* CONSIDERING 40 bar (E124) 30 bar (E024) STATIC PRESSURE ON PISTONE

\*\* CONSIDERING A RANGE OF PUMP 1.5 lpm (E124) AND 1.2 lpm (E024S)

## 1.1 DIMENSIONS

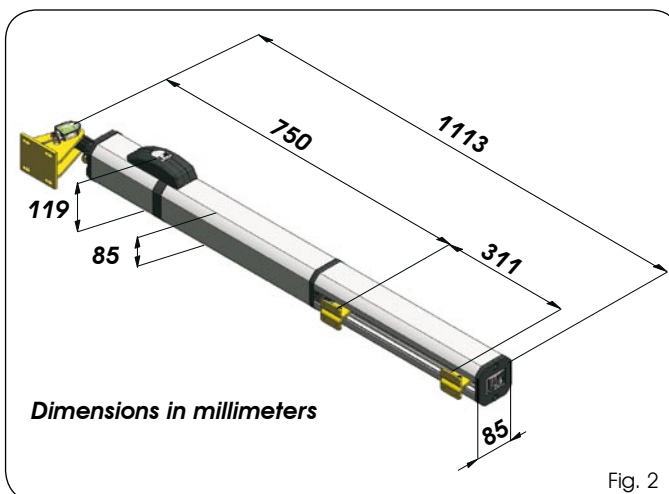
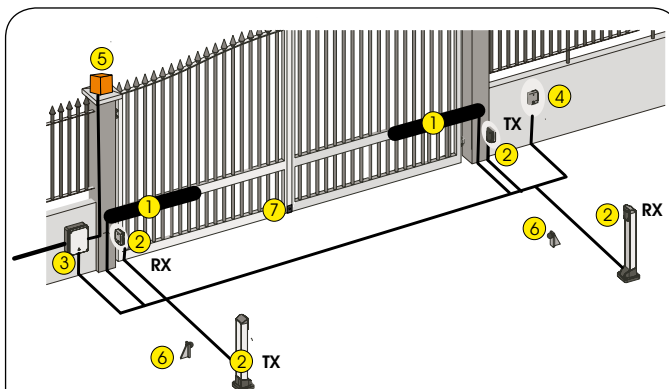

Fig. 2

## 2 PRESETTINGS



- ① S450H operators (**2x2.5 mm<sup>2</sup> each motor**)  
(2x0.5 mm<sup>2</sup> each encoder bus)
- ② RX Photocells (receiver)  
(TRADITIONAL: 4 x 0.5 mm<sup>2</sup>; 2easy bus: 2 x 0.5 mm<sup>2</sup>)
- ② TX Photocells (transmitter) (2 x 0.5 mm<sup>2</sup>)
- ③ Electronic control unit  
(power supply 3 x 1.5 mm<sup>2</sup>)
- ④ Key-operated push-button (e.g. T11) (3 x 0.5 mm<sup>2</sup>)
- ⑤ Flashing lamp 24 V dc (2 x 1 mm<sup>2</sup>)
- ⑥ Opening mechanical stops\*
- ⑦ Electric lock and closing mechanical stop  
(2 x 1.5 mm)

\* Not necessary in case of use of opening mechanical stops inside the operator (Fig. 1 re.⑦)

Fig. 3

## 3 INSTALLATION OF THE AUTOMATED SYSTEM

Following conditions have to be met to ensure safety and the efficient operation of the automated system:

- The gate structure must be suitable for automation. Verify in particular that it is sufficiently strong and stiff and that dimensions and weight correspond to those stated in the technical specifications.
- Verify the smooth and uniform movement of leaves, without irregular friction during the whole travel.
- Verify the good condition of hinges.
- Verify the presence of mechanical limit switches.
- Remove any locks and bolts.

Carry out any metalwork operations before installing the automated system.

- If the gate structure does not allow the stable fixing of the front fitting, create a firm bearing surface in the leaf structure.
- It is advisable to grease all fixing pins - Opening and closing stops must always be installed - Play special attention not to damage the operator rod

**3.2 INSTALLATION DIMENSIONS (Dimensions in millimeters)**

**ATTENTION:** do not cut for any reason the rear bracket

Make reference to figures 4 and 5 and to table 1 to determine the installation position of the operator.

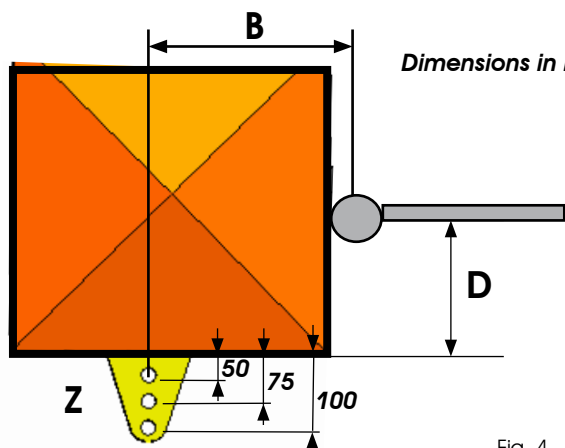

Fig. 4

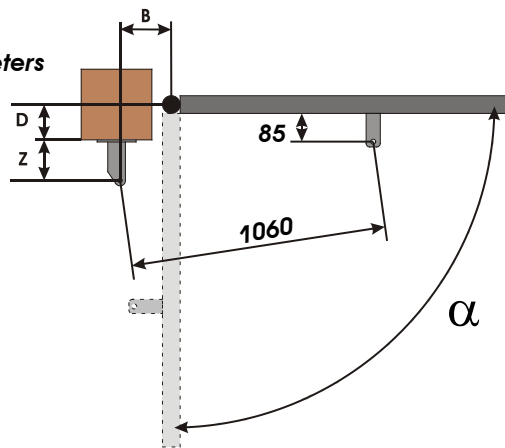

Fig. 5

Dimensions in millimeters

INSTALLATION DIMENSION "B"  
(SEE FIGURE 4-5)

TAB. 1		B	
		XXX	XXXX
D	XXX	120° (3)	120° (3)
	XXX	110° (2)	110° (2)
	XXX	115° (1)	110° (1)

INSTALLATION DIMENSION "D"  
(SEE FIGURE 5)

$\alpha^\circ$  (3)

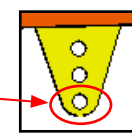

(3)  
HOLE TO BE USED ON THE REAR BRACKET

$\alpha^\circ$  (2)

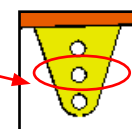

(2)

$\alpha^\circ$  (1)

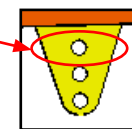

(1)

- INTERSECT THE DIMENSIONS "D" AND "B" TO OBTAIN THE MAXIMUM VALUE OF OPENING GRADES.
- ATTENTION: USE MECHANICAL LIMIT SWITCHES IN ORDER NOT TO EXCEED THE MAXIMUM OPENING GRADES STATED IN TABLE 1 AND GUARANTEE THE CORRECT OPERATION OF THE AUTOMATED SYSTEM.

TAB. 1		B									
		75-84	85-94	95-104	105-114	115-124	125-134	135-144	145-154	155-164	165-175
D	20-24					110° (3)	110° (3)	115° (3)	108° (3)	100° (3)	100° (3)
	25-34					108° (3)	110° (3)	110° (3)	103° (3)	100° (3)	94° (3)
	35-44				100° (3)	107° (3)	108° (3)	104° (3)	111° (2)	104° (2)	100° (2)
	45-54				100° (3)	105° (3)	106° (3)	100° (3)	106° (2)	100° (2)	96° (2)
	55-64			97° (3)	100° (3)	105° (3)	99° (3)	107° (2)	100° (2)	96° (2)	92° (2)
	65-74		93° (3)	97° (3)	100° (3)	100° (3)	110° (2)	101° (2)	96° (2)	102° (1)	98° (1)
	75-84		90° (3)	95° (3)	100° (3)	105° (2)	102° (2)	111° (1)	105° (1)	98° (1)	94° (1)
	85-94	90° (3)	90° (3)	95° (3)	100° (2)	104° (2)	96° (2)	104° (1)	100° (1)	94° (1)	90° (1)
	95-104	90° (3)	90° (3)	95° (3)	100° (2)	96° (2)	106° (1)	98° (1)	96° (1)	90° (1)	
	105-114	90° (3)	90° (3)	95° (2)	97° (2)	103° (1)	99° (1)	94° (1)	92° (1)		
	115-124	90° (3)	90° (2)	95° (2)	98° (1)	100° (1)	94° (1)				
	125-134	90° (2)	90° (2)	95° (1)	98° (1)	94° (1)					
	135-144	90° (2)	90° (2)	95° (1)	94° (1)						
	145-154	90° (1)	90° (1)	94° (1)							
	155-164	90° (1)	90° (1)								
165-170	90° (1)										

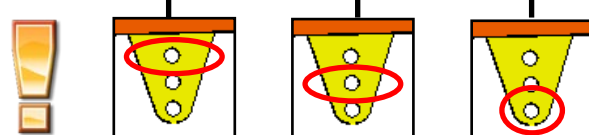

HOLE TO BE USED ON THE REAR BRACKET

**3.3 INSTALLATION OF OPERATORS**

1. Check the perfect level then weld the rear fitting to the pillar or fix it by means of suitable screws, dowels / threaded inserts. Observe the dimensions stated in Tab.1 (**never cut the rear fitting; moreover it must be installed with the word "UP" facing up as shown in figure 6 re. ①**).

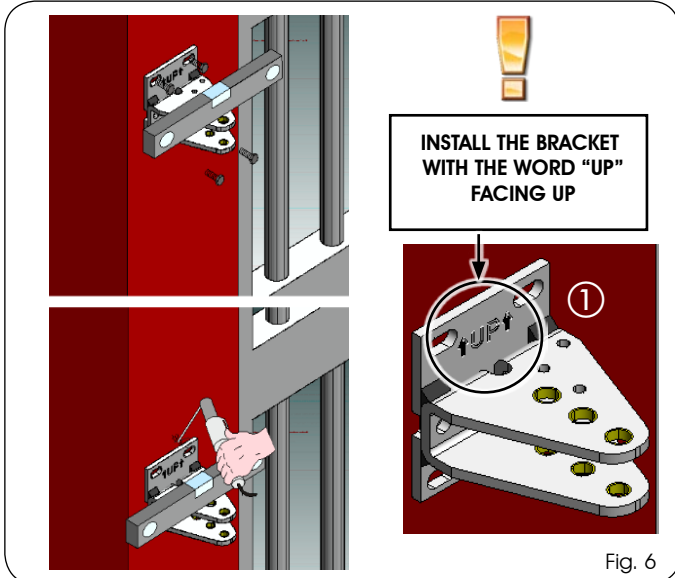

Fig. 6

2. By means of table 1 (see white or grey boxes) choose the fixing hole on the rear bracket and install the fork (Fig. 7 re. ①) by assembling it with the special pin supplied (Fig. 7 re. ②).

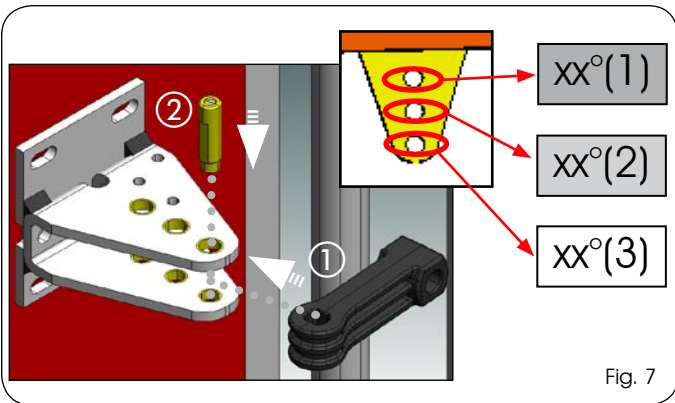

Fig. 7

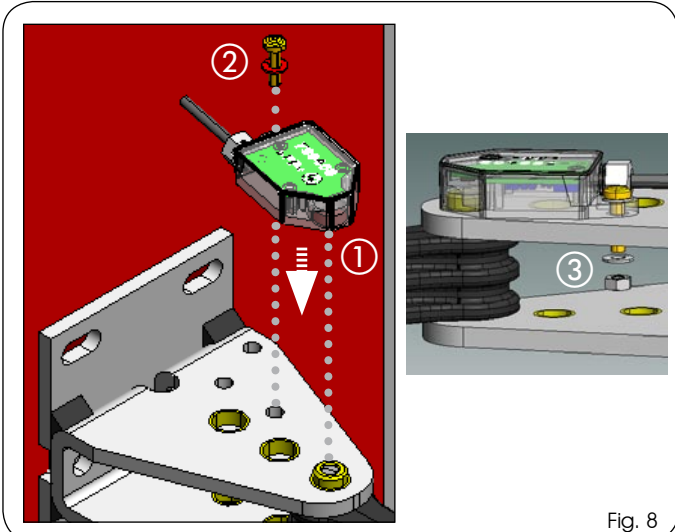

Fig. 8

3. Install the encoder on the rear bracket by correctly engaging it on the pin then fix it with the screw and nut supplied (Fig. 8 re. ① ② ③).
4. Slightly press the protection cover on the rear bracket to install it (Fig. 9).
5. Assemble the operator and the rear bracket by means of the pin and nut supplied (Fig. 10 re. ① - ②).

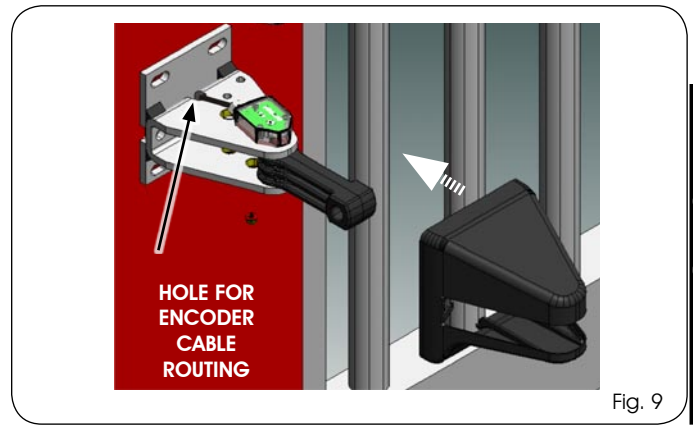

Fig. 9

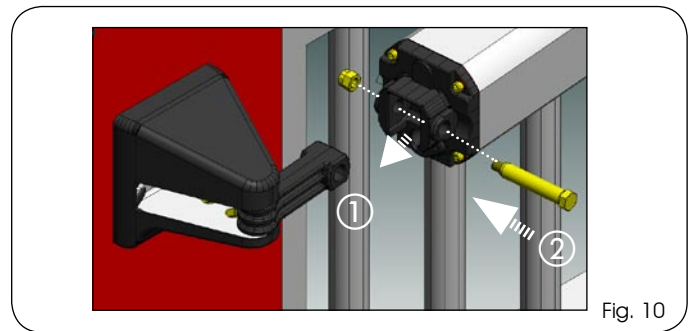

Fig. 10

6. Screw one-half of the thread of the front articulated joint on the operator rod and tighten the nut (Fig. 11 re. ①).
7. Unlock the operator according chapter 4.
8. **If no external mechanical stop point at closure is present, you may use the stop point inside the operator. Therefore remove the rod completely up to its internal stop point.**
9. **If an external mechanical stop point at closure is present, remove the rod completely and then insert it 5 mm.**

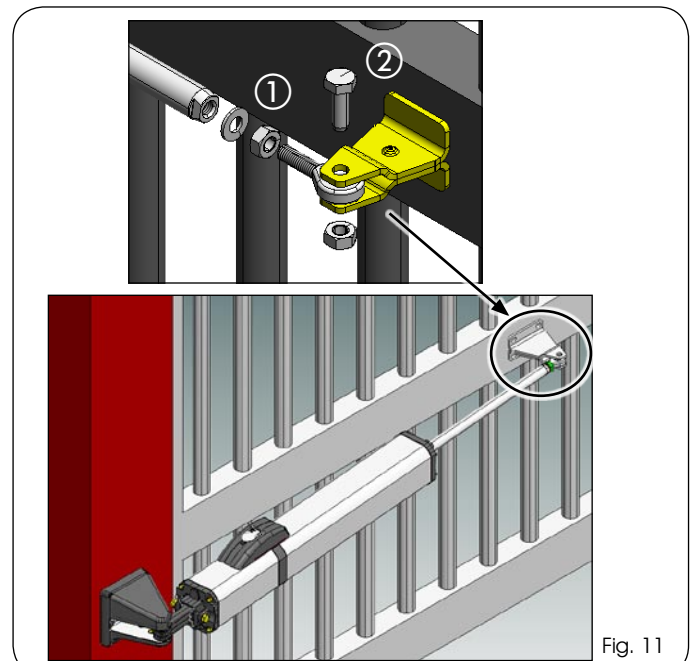

Fig. 11

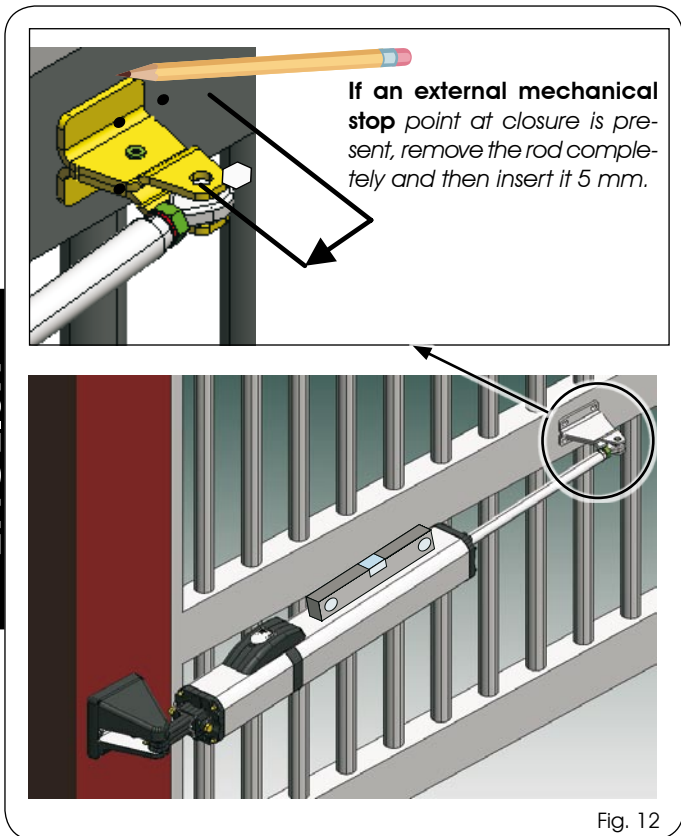

Fig. 12

10. Close the gate leaf and install the front fitting on the rod as shown in Fig. 11 re. ②.
11. Establish the fixing position of the front fitting on the leaf and mark the fixing points (Fig. 12) (the operator must be perfectly level).
12. Disassemble the operator from the front fixing to avoid damaging the rod when the front fixing is installed on the gate.
13. Weld the front fixing directly on the leaf or screw it by means of threaded inserts.
14. If an opening mechanical stop on ground is not installed, spacers can be used (Fig. 1 re. ⑦). Remove the front articulated joint and insert on the rod the number of spacers required to reach the desired opening angle (Fig. 14).

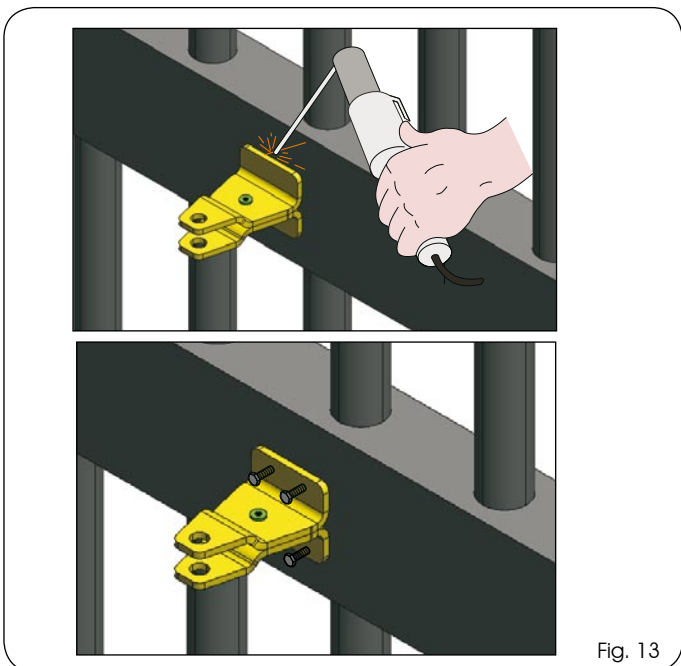

Fig. 13

15. Secure the operator to the front fixing (Fig. 15).
16. Install the metallic protection cover as shown in Fig. 16.
17. Connect the cable to the operator using the two screws supplied, as shown in Fig. 17.

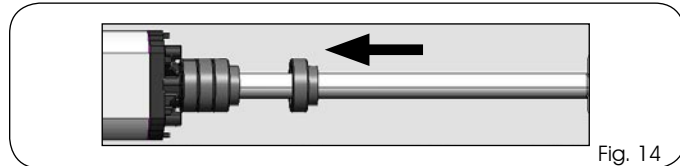

Fig. 14

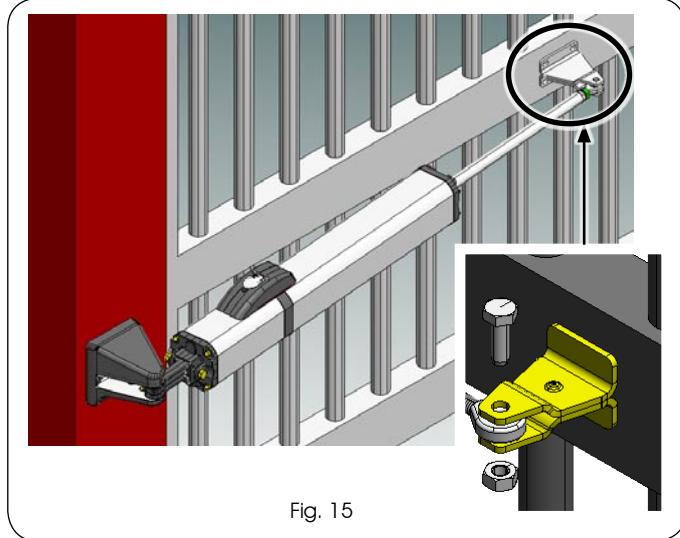

Fig. 15

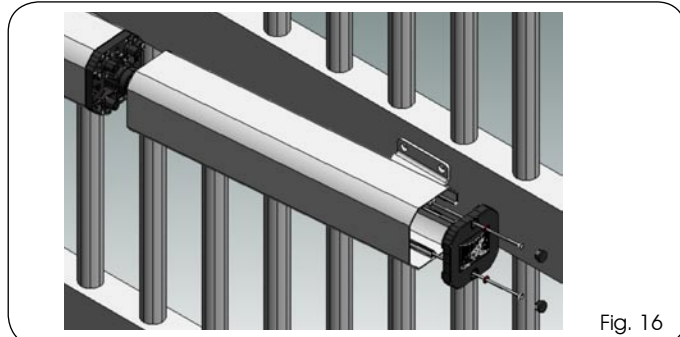

Fig. 16

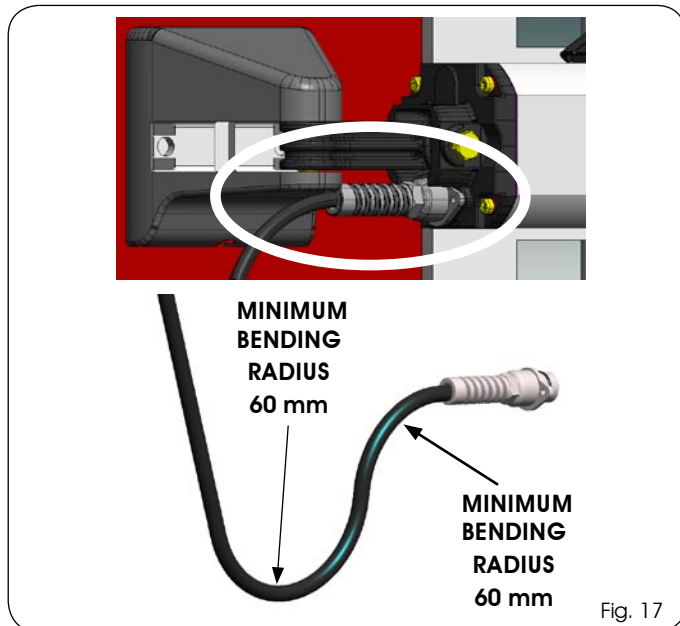

Fig. 17

**4 MANUAL OPERATION**

If the gate is to be operated manually because of a power failure or an automated system fault, activate the release device.

1) Lift the protection lid (Fig. 18, re. ①) and insert the key in the lock (Fig. 18, re. ②).

2) Turn the key 90° clockwise to open the cover and lift it.

3) Turn the release knob (Fig. 18, re. ③) anticlockwise until it stops.

4) Open or close the leaf manually.

To restore the normal operation of the automated system, perform the above described operations in reverse order.

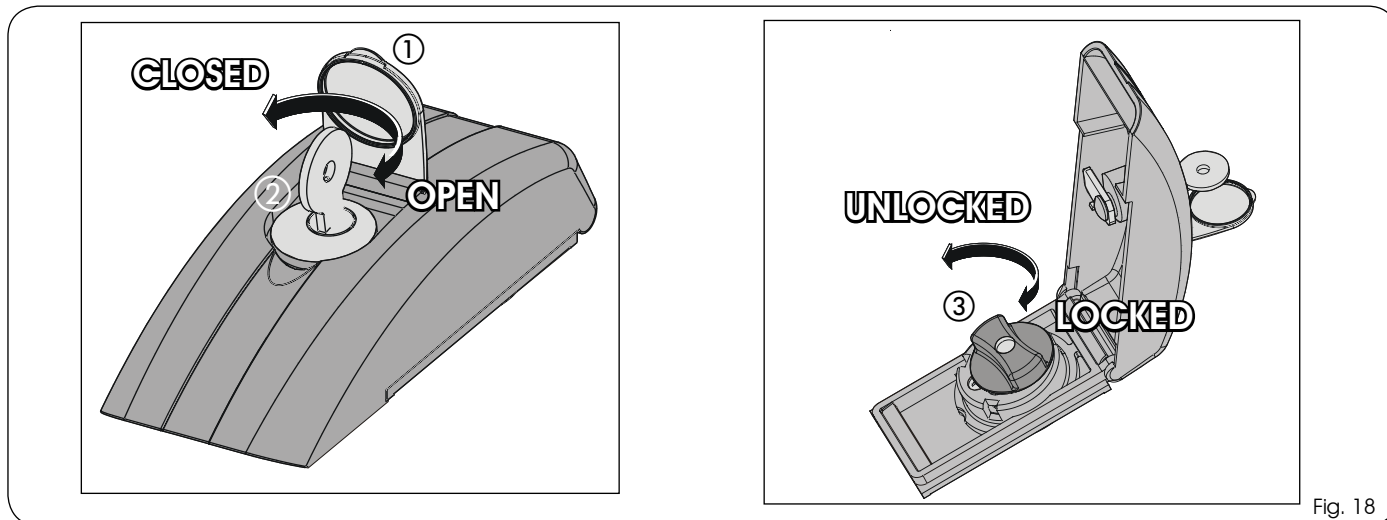

Fig. 18

**5 ELECTRICAL CONNECTION OF THE "2easy bus" ENCODER**

The S450H operator is fitted with an encoder system with "2easy bus" technology. The proper assignment of the leaf to the corresponding encoder depends on the connection of the two encoder wires (leaf 1 - encoder 1; leaf 2 - encoder 2).

THE ENCODER WIRES MUST BE CONNECTED TO THE "2easy bus" CONNECTOR OF THE ELECTRONIC EQUIPMENT.

To verify the proper combination **LEAF 1 - ENCODER 1 - MOTOR 1** and **LEAF 2 - ENCODER 2 - MOTOR 2**, refer to the LEDs on the encoders, as shown by table 2 and the figures 19 - 20 - 21.

To invert the leaf-encoder combination, change the encoder polarity by swapping its wires until the right LEDs are lit.



The LEDs of the encoder remain visible also with the protection cover of the rear bracket installed.

**DL 1: must always be ON** to ensure the right connection between encoder and board.

**DL 2: indicates the leaf where the encoder is installed.**

If the encoder is installed on leaf 1, the DL 2 LED is ON.

If the encoder is installed on leaf 2, the DL 2 LED is OFF.

**DL 3: when blinking** at regular intervals, it signals the pulse reading **during the leaf movement. When the gate leaf is stationary, DL 3 is OFF.**

TABLE 2

LED	ON	BLINKING	OFF
DL 1	Power supply ON and BUS - board communication	Power supply ON but no BUS communication (e.g.: cabling fault)	Power supply OFF and no BUS communication (e.g.: missing or broken connection)
DL 2	Encoder associated to leaf 1	/	Encoder associated to leaf 2
DL 3	/	Pulse reading during leaf movement	Leaf stationary

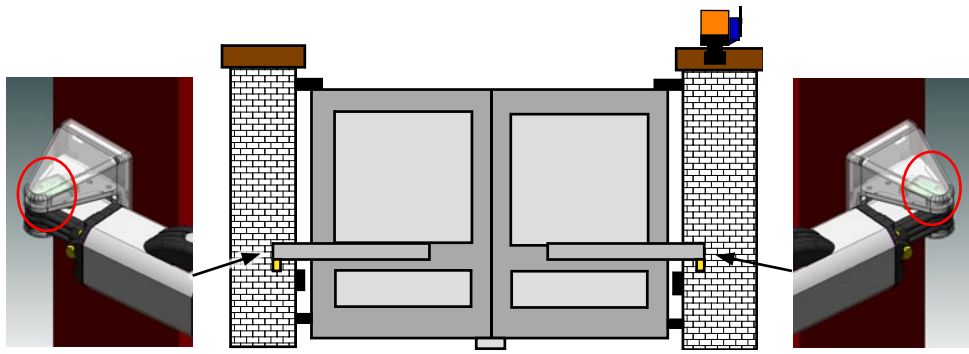

Fig. 19

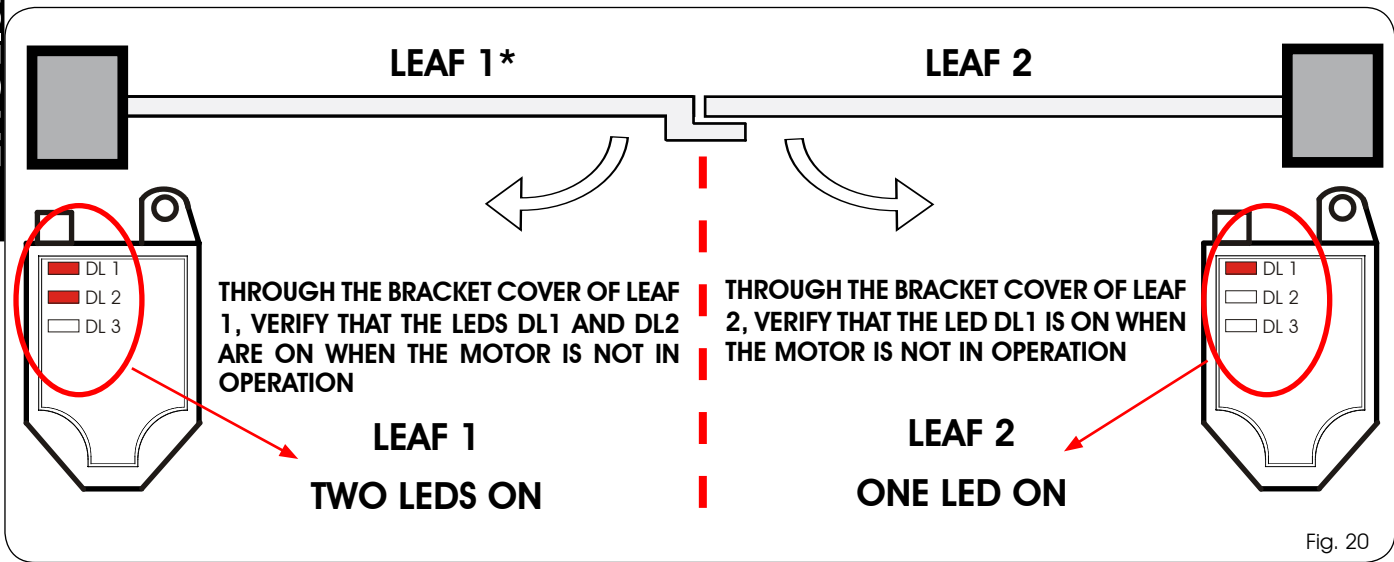

Fig. 20

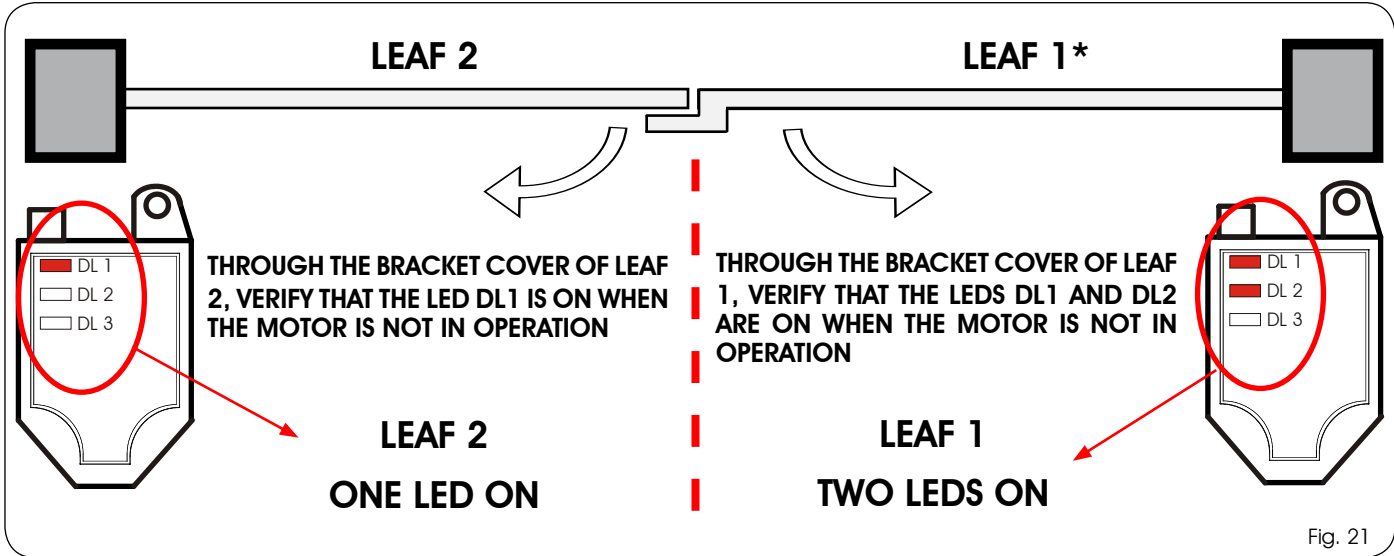

Fig. 21

**✎** \* LEAF 1 OPENS FIRST AND CLOSES AFTER LEAF 2. IF LEAF 1 AND LEAF 2 DO NOT OVERLAP, ON THE ELECTRONIC CONTROL BOARD, IF AVAILABLE, THE LEAF DELAY CAN BE SET TO ZERO.

**✎** BY SWAPPING THE ENCODER WIRES, THE ENCODER ASSOCIATED TO LEAF 1 CAN BE COUPLED TO LEAF 2 AND VICE VERSA (see example Fig. 22)

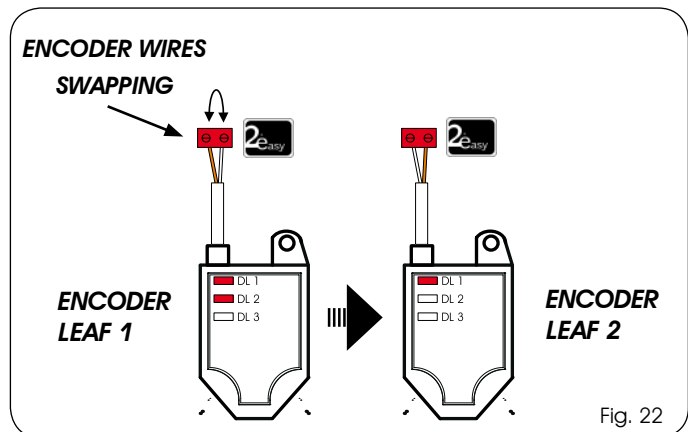

Fig. 22