



## E124 control unit – rapid guide

### WARNINGS

- Important! For the safety of people, it is important that all the instructions be carefully observed.
- Incorrect installation or incorrect use of the product could cause serious harm to people.
- Carefully read the instructions before beginning to install the product and keep them for future reference.
- The symbol  indicates notes that are important for the safety of persons and for the good condition of the automated system.
- The symbol  draws your attention to the notes on the characteristics and operation of the product.
- Before attempting any work on the control unit (connections, maintenance), always turn off power.
- Install, upstream of the system, a differential thermal breaker with adequate tripping threshold,
- Connect the earth cable to the relevant terminal.
- Always separate power cables from control and safety cables (push-button, receiver, photocells, etc.). To avoid any electrical disturbance, use separate sheaths or a screened cable (with the screen earthed).

### CE DECLARATION OF CONFORMITY

**Manufacturer:** FAAC S.p.A.  
**Address:** Via Calari, 10 - 40069 Zola Predosa BOLOGNA - ITALY  
**Declares that:** The E124 control unit

- conforms to the essential safety requirements of the following EEC directives

2006/95/EC Low Voltage Directive  
 2004/108/EC Electromagnetic Compatibility Directive

Additional note:

This product underwent tests in a typical uniform configuration  
 (all products manufactured by FAAC S.p.A.).

Bologna, 01 March 2010

The Managing Director  
 A. Marcellan

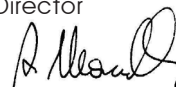

### TECHNICAL SPECIFICATIONS

<b>Primary power feed from mains</b>	with switching power feed 230/115 V~ - 50/60 Hz
<b>Secondary power feed</b>	24 Vdc - 16 A max. (min. 20 Vdc. - max. 28 Vdc.)
<b>Power absorbed from mains</b>	stand-by = 4W max. ~ 400 W
<b>Max. load for motor</b>	7 A
<b>Power feed for accessories</b>	24 Vdc
<b>Accessories max. current</b>	24Vdc max. 500 mA BUS-2EASY max. 500 mA
<b>Battery charge current</b>	180 mA
<b>Operating ambient temperature</b>	(-20 - +55) °C
<b>Protective fuses for unit</b>	All self resetting
<b>Protective fuses for power pack</b>	2.5 A
<b>Function logics</b>	Semiautomatic, Automatic, "step-by-step" Semiautomatic, Automatic with reverse during pause, Automatic step-by-step, Safety devices automatic, Safety devices step-by-step automatic, "b" Semiautomatic, mixed logic "bC", Dead-man, Automatic with timer function
<b>Work time</b>	Programmable (from 0 to 9 min 50 sec)
<b>Pause time</b>	Programmable (from 0 to 9 min 50 sec)
<b>Motor power</b>	Programmable on 50 levels
<b>Motor speed</b>	Programmable on 10 levels

<b>Connector inputs</b>	Switching feeder, Battery, Decoder/Minidec/RP, X-COM, module XF433/868, USB
<b>Terminal board inputs</b>	BUS-2EASY, Inputs from IN1 to IN5, Travel limit device, Encoder.
<b>Terminal board outputs</b>	Flashing lamp, Motors, Electrical lock, OUT1, OUT2 (programmable), power feed to accessories
<b>Programming</b>	1st and 2° lev. with 3 keys (+, -, F) and LCD display. 3rd lev. with P.C. connected via <b>USB</b> or with <b>X-COM</b> module.

 **These instructions are to be considered as a rapid guide for installation. The complete instructions can be downloaded at the following address: [www.faacgroup.it](http://www.faacgroup.it)**

 **To access PROGRAMMING FROM PC, use the X-COM module or connect the USB cable to the dedicated connector and consult the dedicated instructions.**

LAYOUT AND COMPONENTS OF E124

ENGLISH

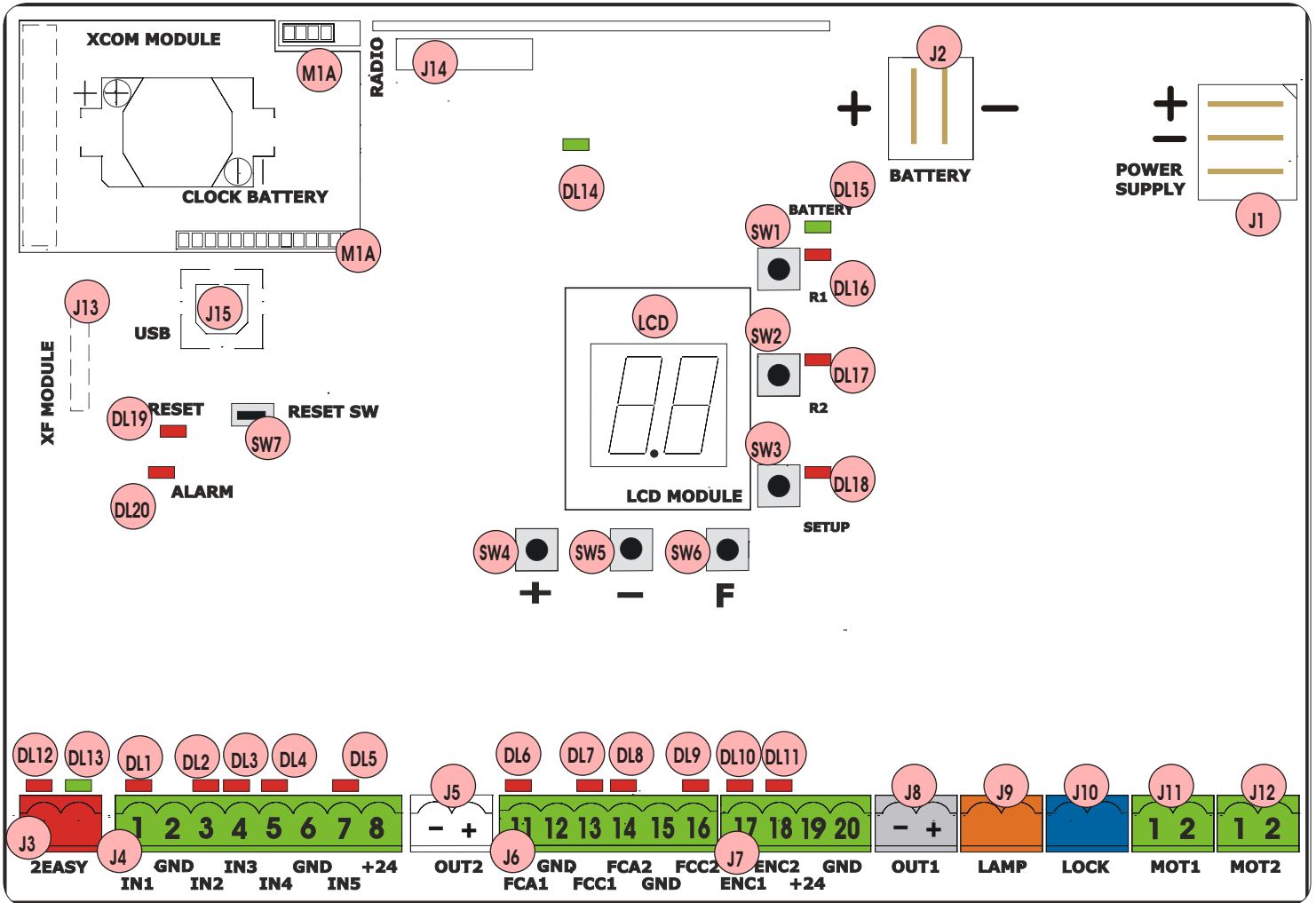

DESCRIPTION OF COMPONENTS

<b>LCD</b>	SIGNALS AND PROGRAMMING DISPLAY
<b>SW1</b>	"R1" PROGRAMMING PUSH-BUTTON
<b>SW2</b>	"R2" PROGRAMMING PUSH-BUTTON
<b>SW3</b>	"SETUP" PUSH-BUTTON
<b>SW4</b>	"+" PROGRAMMING PUSH-BUTTON
<b>SW5</b>	"-" PROGRAMMING PUSH-BUTTON
<b>SW6</b>	"F" PROGRAMMING PUSH-BUTTON
<b>SW7</b>	"RESET SW" SOFTWARE RESET PUSH-BUTTON
<b>DL1</b>	INPUT STATUS CONTROL LED "IN1"
<b>DL2</b>	INPUT STATUS CONTROL LED "IN2"
<b>DL3</b>	INPUT STATUS CONTROL LED "IN3"
<b>DL4</b>	INPUT STATUS CONTROL LED "IN4"
<b>DL5</b>	INPUT STATUS CONTROL LED "IN5"
<b>DL6</b>	INPUT STATUS CONTROL LED "FCA1"
<b>DL7</b>	INPUT STATUS CONTROL LED "FCC1"
<b>DL8</b>	INPUT STATUS CONTROL LED "FCA2"
<b>DL9</b>	INPUT STATUS CONTROL LED "FCC2"
<b>DL10</b>	INPUT STATUS CONTROL LED "ENC1"
<b>DL11</b>	INPUT STATUS CONTROL LED "ENC2"
<b>DL12</b>	SIGNALLING LED FOR DEVICE <b>BUS-2EASY</b> ACTIVE
<b>DL13</b>	SIGNALLING LED FOR <b>BUS 2-EASY</b> DIAGNOSTICS
<b>DL14</b>	LED SIGNALLING PRIMARY POWER ON
<b>DL15</b>	LED SIGNALLING SECONDARY POWER ON

<b>DL16</b>	SIGNALLING LED FOR "SW1" PUSH-BUTTON (R1 PUSH-BUTTON)
<b>DL17</b>	SIGNALLING LED FOR "SW2" PUSH-BUTTON (R2 PUSH-BUTTON)
<b>DL18</b>	SIGNALLING LED FOR "SW3" PUSH-BUTTON (SETUP PUSH-BUTTON)
<b>DL19</b>	PRESSURE SIGNALLING LED "RESET SW" PUSH-BUTTON
<b>DL20</b>	ALARM SIGNALLING LED "ALARM"
<b>J1</b>	POWER FEEDER SWITCHING CONNECTOR (PRIMARY POWER)
<b>J2</b>	SECONDARY POWER SELECTOR
<b>J3</b>	CONNECTOR FOR CONNECTION TO BUS-2EASY DEVICES
<b>J4</b>	CONNECTOR FOR TERMINAL BOARD INPUTS
<b>J5</b>	CONNECTOR FOR OUT2 OUTPUT (see 2nd level prog.)
<b>J6</b>	TRAVEL LIMITS CONNECTOR
<b>J7</b>	CONNECTOR FOR LEAF 1 AND LEAF 2 ENCODER INPUTS
<b>J8</b>	CONNECTOR FOR OUT1 OUTPUT (see 2nd level prog.)
<b>J9</b>	FLASHING LAMP OUTPUT CONNECTOR
<b>J10</b>	CONNECTOR FOR ELECTRICAL LOCK OUTPUT
<b>J11</b>	LEAF 1 MOTOR CONNECTOR
<b>J12</b>	LEAF 2 MOTOR CONNECTOR
<b>J13</b>	CONNECTOR FOR RECEIVER MODULE XF433/XF868
<b>J14</b>	CONNECTOR: DECODER / MINIDEC / RP RECEIVER
<b>J15</b>	USB CONNECTOR FOR PROGRAMMING FROM PC
<b>M1A</b>	MODULE X-COM CONNECTOR

**POWER FEED**

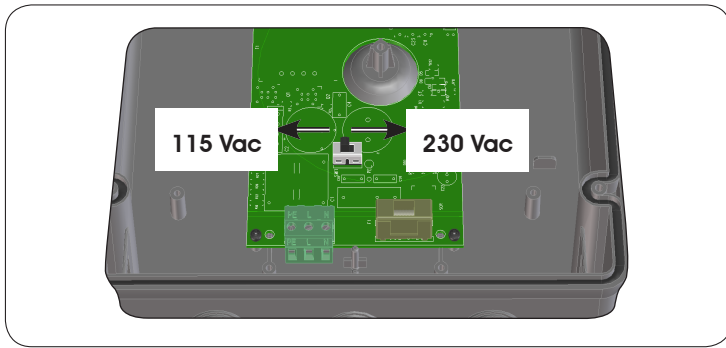

**J1:** Select the correct power feed, by turning the power switching selector to its correct position (Default 230 Vac.)

 **To ensure correct operation, the switching feeder must be connected to the earth conductor in the system. Install an adequate differential thermal breaker upstream of the system.**

**SECONDARY POWER FEED**

**J2:** In the absence of a primary feed from the mains, the control unit can be fed by a secondary low voltage (24Vdc) power feed. Power can be supplied by a pack of batteries, recharged by a battery charger integrated in the board, or by a stabilised power feeder. In both cases, the power supply must have the following characteristics:

**Voltage: (24 ± 4) Vdc**  
**Current: 16 A max.**

 **If you use an external stabilised feeder, you must disable the “battery charger” function via the PC (see dedicated instructions).**

**INPUTS DEFAULT SETTING**

**Terminal-board J4**

IN1	OPEN A	N.O. contact
IN2	OPEN B	N.O. contact
IN3	STOP	N.C. contact
IN4	FSW OP	N.C. contact
IN5	FSW CL	N.C. contact

**Connector J13 – XF Module (OMNIDEC)**

Channel 1	OPEN A
Channel 2	OPEN B

**Connector J14 - Radio**

Channel 1 RP	OPEN A
Channel 2 RP2	OPEN B

**TERMINAL BOARD MOTORS**

**J11 (MOT1):** Connection of motor connected to leaf 1, i.e. the leaf which opens first during an opening operation.

**J12 (MOT2):** Connection of the motor connected to leaf 2, i.e. the leaf which opens second.

 **If only one motor is connected, it must be connected to terminal J11 (MOT1).**

 **If, during the first movement of the SETUP procedure, the leaves open instead of closing, the motor connection cables must be changed over.**

**LED OPERATION**

LED	Description	ON (contact closed)	OFF (contact open)
DL1	IN1 - OPEN A	Command enabled	Command disabled
DL2	IN2 - OPEN B	Command enabled	Command disabled
DL3	IN3- STOP	Command disabled	Command enabled
DL4	IN4 - FSW OP	Safety devices disabled	Safety devices tripped
DL5	IN5 - FSW CL	Safety devices disabled	Safety devices tripped
DL6	FCA1	Opening travel-limit devices free	Opening travel-limit devices engaged
DL7	FCC1	Closing travel-limit devices free	Closing travel-limit devices engaged
DL8	FCA2	Opening travel-limit devices free	Opening travel-limit devices engaged
DL9	FCC2	Closing travel-limit devices free	Closing travel-limit devices engaged
DL10	ENC1	Flashing during operation	
DL11	ENC2	Flashing during operation	
DL12	SIGNALLING LED FOR DEVICE <b>BUS-2EASY</b> ACTIVE		
DL13	SIGNALLING LED FOR <b>BUS 2-EASY</b> DIAGNOSTICS		
DL14	LED SIGNALLING PRIMARY POWER ON		
DL15	LED SIGNALLING SECONDARY POWER ON		
DL16	SIGNALLING LED FOR “SW1” PUSH-BUTTON (R1 PUSH-BUTTON)		
DL17	SIGNALLING LED FOR “SW2” PUSH-BUTTON (R2 PUSH-BUTTON)		
DL18	SIGNALLING LED FOR “SW3” PUSH-BUTTON (SETUP PUSH-BUTTON)		
DL19	PRESSURE SIGNALLING LED “RESET SW” PUSH-BUTTON		
DL20	ALARM SIGNALLING LED “ALARM”		

 **Flashing LED ALARM indicates alarm in progress (a situation which does not prejudice gate operation)**

 **LED ALARM on steady light indicates error in progress (a situation which blocks operation until cause of error is eliminated)**

ELECTRICAL CONNECTIONS

ENGLISH

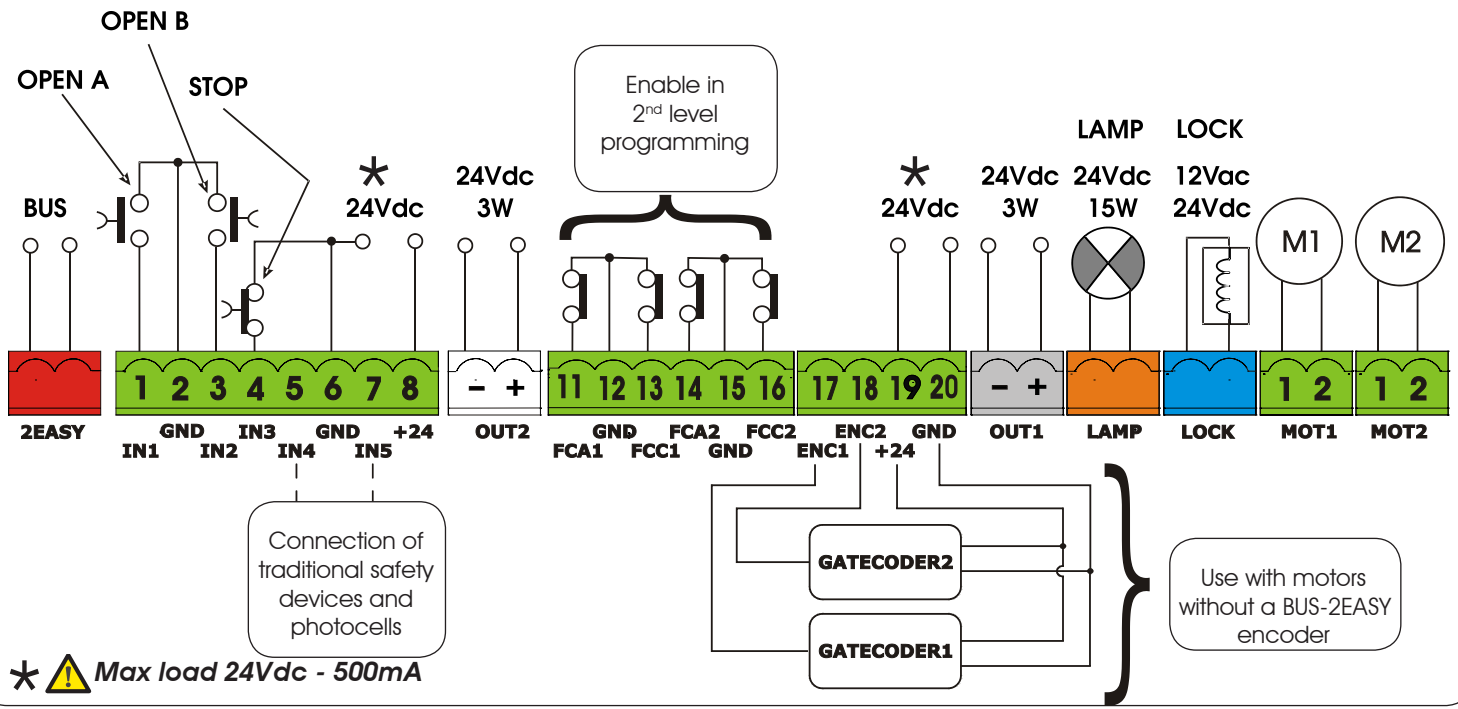

CONNECTION OF TRADITIONAL SAFETY DEVICES

With the E124 control unit, you can use both traditional photocells (N.C. contact with relay) and/or photocells with BUS-2EASY (open collector contact).

The following table shows the programming operations of the dip-switch inside the transmitter and the BUS 2-EASY photocells receiver.

Connection of no safety device and STOP

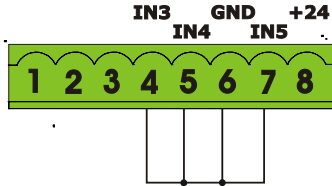

Connection of a pair of closing photocells and a pair of opening/closing photocells with disabled FAIL-SAFE safety device and STOP

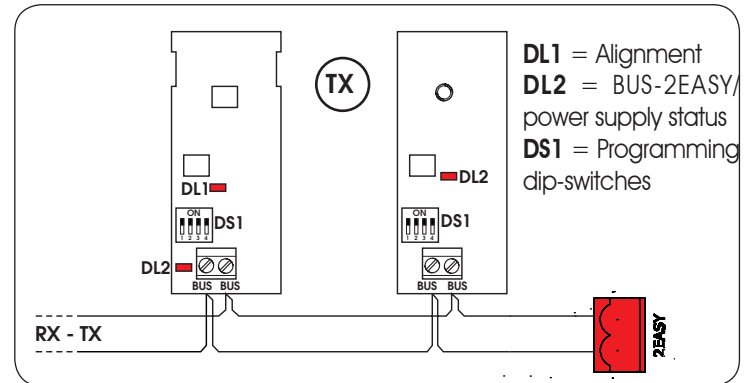
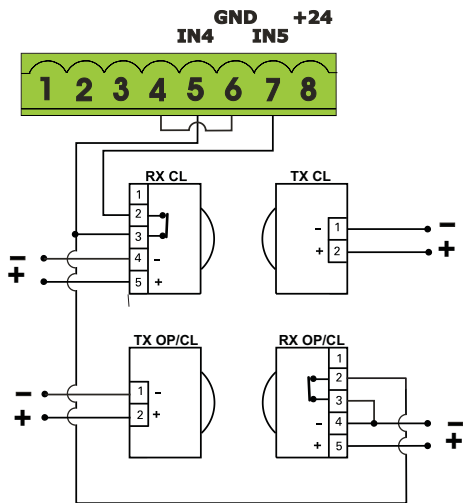

PHOTOCELLS BUS-2EASY

ADDRESSING THE BUS-2EASY PHOTOCELLS

Important: the same address must be given to both transmitter and receiver. Make sure that there are not two or more photocell pairs with the same address. If you are not using any BUS-2EASY accessory, leave free connector BUS-2EASY

Dip1	Dip2	Dip3	Dip4	Rif.	Type
OFF	OFF	OFF	OFF	B - C	OPENING
OFF	OFF	OFF	ON		
OFF	OFF	ON	OFF		
OFF	OFF	ON	ON		
OFF	ON	ON	OFF	D	CLOSING
OFF	ON	ON	ON		
ON	OFF	OFF	OFF		
ON	OFF	OFF	ON		
ON	OFF	ON	OFF	A	OPENING and CLOSING
ON	OFF	ON	ON		
ON	ON	OFF	OFF		
ON	ON	OFF	ON		
OFF	ON	OFF	OFF	/	OPEN PULSE
OFF	ON	OFF	ON		
ON	ON	ON	ON		

**MEMORY STORAGE OF BUS-2EASY ACCESSORIES**

1. Cut power to the board.
2. Connect the two cables of the BUS-2EASY accessories to the red terminal-board J3 (any polarity will do).
3. Power the board, taking care to first connect connector J1 of the main power supply (coming from the switching feeder) and then, connector J2 of any batteries.
4. Quickly press once only the SETUP (SW3) push-button, to execute learning. Check operation of the installed BUS-2EASY devices.

**Description of LED DL12 (RED)**

<b>ON</b>	Safety device engaged or pulse generator active
<b>OFF</b>	NO safety device engaged and NO pulse generator active

**Description of LED DL13 (GREEN)**

<b>Steady light</b>	Normal activity (LED Lighted even if no photocells)
<b>OFF</b>	Line BUS-2EASY short circuiting (flash every 2.5 sec.)
<b>Fast flashing</b>	Error detected in BUS-2EASY connection, repeat the acquisition procedure. If the error is repeated, make sure that there is not more than one accessory with the same address in the system (also see the accessories instructions).

**ADDRESSING THE BUS-2EASY ENCODERS**

Connection of the BUS-2EASY input in the control board is via the bipolar cables which come out of the encoders.

**⚠ Unlike the case of the photocell devices, the polarity of the BUS-2EASY line connection determines whether the encoder belongs to one leaf rather than to the other.**

**ENCODER WIRING FOR OPERATOR S700H**

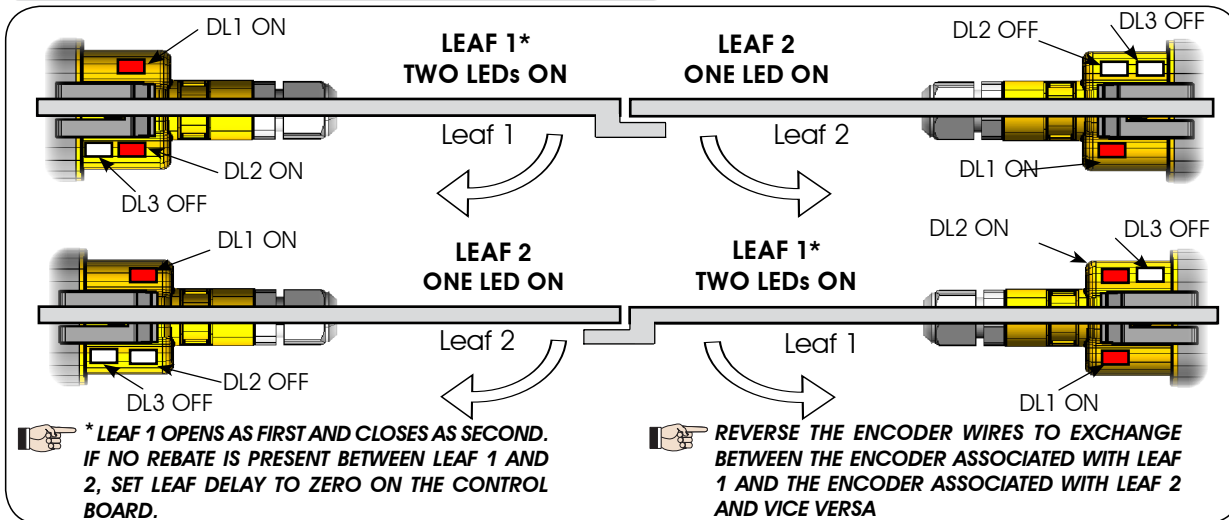

**ENCODER WIRING FOR OPERATOR S450H**

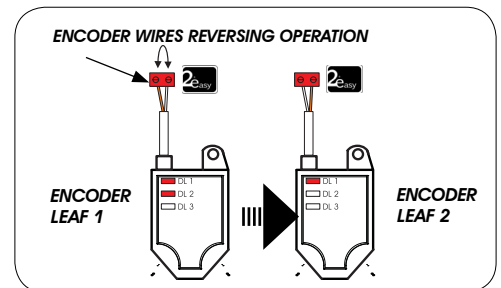
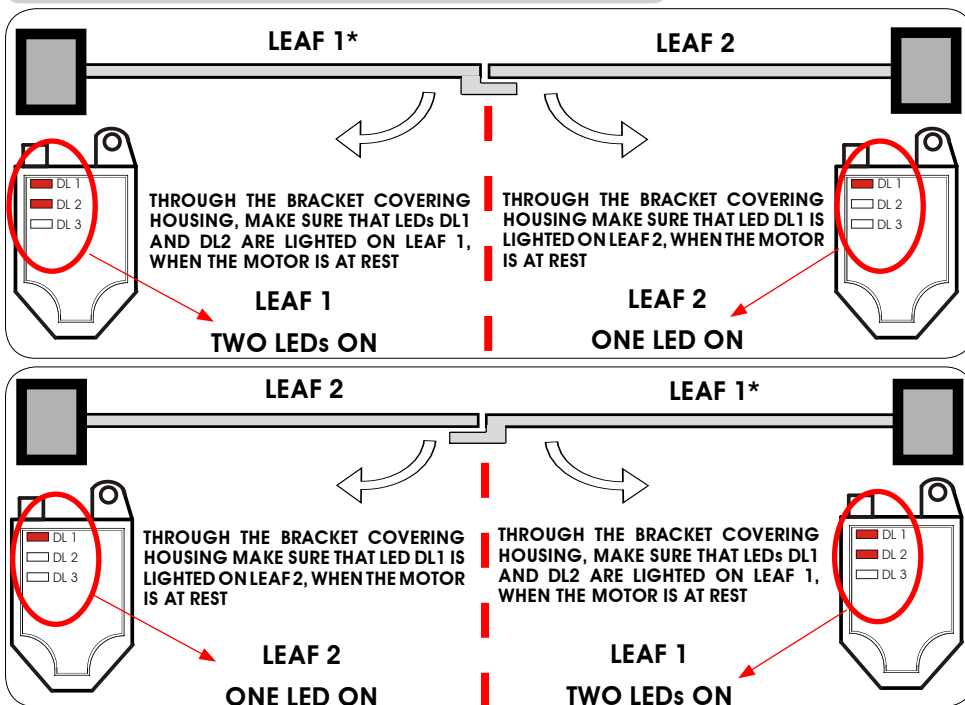

**\* LEAF 1 OPENS AS FIRST AND CLOSES AS SECOND. IF THERE IS NO REBATE BETWEEN LEAF 1 AND 2, SET THE LEAF DELAY TO ZERO ON THE CONTROL BOARD.**

**REVERSE THE ENCODER WIRES TO EXCHANGE BETWEEN THE ENCODER ASSOCIATED WITH LEAF 1 AND THE ENCODER ASSOCIATED WITH LEAF 2, AND VICE VERSA**

## CONNECTOR J13 – XF MODULE RAPID CONNECTION

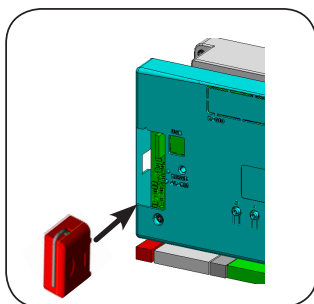

The control unit has an integrated 2-channel decoding system (DS, SLH, LC/RC) named OMNIDEC. This system makes it possible to save – through an extra receiver module – XF433 or XF868 radio commands of the same frequency, but of a different type (DS, SLH, LC/RC). It is possible to save both total opening (OPEN A) and partial opening (OPEN B) of the automated system, up to a maximum of 256 channels.

**⚠ Insert and remove the boards only after cutting power.**

## SAVING DS RADIO CONTROLS

1. On the DS radio control, select the required ON-OFF combination for the 12 dip-switches.
2. Press push-button R1 (SW1) or R2 (SW2) to save respectively total opening (OPEN A) or partial opening (OPEN B). The relevant LED starts to flash slowly for 5 sec.
3. Release the push-button.
4. Within these 5 sec., press the appropriate push-button on the radio control.
5. The relevant LED lights up on steady beam for 1 second and then goes OFF, indicating that storage was executed.
6. To add other different codes, repeat the procedure from point 1.
7. To add radio controls with the same code, copy the same ON-OFF combination on the other radio controls.

## SAVING SLH RADIO CONTROLS

1. On the SLH radio control, simultaneously press and hold down push-buttons P1 and P2.
2. The radio control LED begins to flash.
3. Release both push-buttons.
4. Press push-button R1 (SW1) or R2 (SW2) to save respectively total opening (OPEN A) or partial opening (OPEN B). The relevant LED starts to flash slowly for 5 sec.
5. Release the push-button.
6. Within these 5 sec., while the radio control LED is still flashing, press and hold down the required push-button on the radio control (the radio control LED lights up on steady beam).
7. The LED on the board lights up on steady beam for 1 second and then goes OFF, indicating that storage was executed.
8. Release the radio control push-button.
9. Quickly press twice the push-button of the saved radio control.

## MEMORY STORAGE OF THE LC/RC RADIO CONTROLS

1. Use LC/RC remote controls only with a 433 MHz receiver module.
2. Press push-button R1 (SW1) or R2 (SW2) to save respectively total opening (OPEN A) or partial opening (OPEN B). The relevant LED starts to flash slowly for 5 sec.
3. Release the push-button.
4. Within these 5 sec., press the appropriate push-button on the LC/RC remote control.
5. The LED lights up on steady beam for 1 second, indicating memory storage executed, and then resumes flashing for another 5 sec., during which another radio control can be memory stored.
6. When the 5 sec. have elapsed, the LED goes OFF indicating the end of the procedure.
7. To add other radio controls, repeat the operation at point 1

## PROGRAMMING

To program the operation of the automated system, you must access the "PROGRAMMING" mode.

Programming is in two parts: 1st LEVEL, 2nd LEVEL.

**⚠ On activation of the board, the display shows **b0** and, for 3 seconds, the fw version of the board.**

**The status of the automated system is shown on the display. If "PC" appears on the display when the F push-button is pressed, this means that programming with the PC is loaded on the board. If no password was set, you can only modify parameters **L0-PA-Pb**. To modify the other programming parameters, reload the default of the motor used (in this case the PC programming will be replaced by the default parameters of the board)**

**⚠ If dF appears on the display when you press key F (and hold it down), this means that you have entered 1st level programming.**

**☞ Modification of the programming parameters is immediately effective, whereas definitive memory-storage occurs only on exiting programming and returning to the view of the inputs status. If you cut power to the equipment before returning to view the inputs status, all the modifications made will be lost.**







**☞ You can return to the inputs status display, and save all the parameters modified up till then, from any point of 1st and 2nd level programming by simultaneously pressing keys F and -.**

**☞ To restore the default settings, recharge the required default during the first passage of 1st level programming.**

1<sup>ST</sup> LEVEL PROGRAMMING



Display	Function	Default 0	Default 1	Default 2	Default 3	Default 4	Default 5
dF	<p><b>DEFAULT:</b></p> <p><b>0</b> Configures the parameters with DEFAULT values corresponding to an installation with non-FAAC operators. (see default column 0).</p> <p><b>1</b> Configures the parameters with DEFAULT values corresponding to an installation with operators <b>FAAC 412, 413/415, 770, 390</b> (see default column 1).</p> <p><b>2</b> Configures the parameters with DEFAULT values corresponding to an installation with operators <b>FAAC 391</b> (see default column 2).</p> <p><b>3</b> Configures the parameters with DEFAULT values corresponding to an installation with operators <b>FAAC S700H</b> (see default column 3).</p> <p><b>4</b> Configures the parameters with DEFAULT values corresponding to an installation with operators <b>FAAC 418</b>. (see column default 4).</p> <p><b>5</b> Configures the parameters with DEFAULT values corresponding to an installation with operators <b>FAAC S450H</b> (see column default 5).</p> <p><b>CU</b> If the <b>CU</b> value appears when you release the <b>F</b> push-button, this means that a standard configuration modified by push-buttons and display was selected. If you wish to maintain this programming, press push-button <b>F</b> again.</p> <p><b>PC</b> If the <b>PC</b> value appears when you release the <b>F</b> push-button, this means that programming from the PC was effected with the default password (0000). By pressing the + and - keys, you can load a default configuration from among those listed above. If you wish to maintain programming from the PC, press push-button <b>F</b> again.</p>	0	1	2	3	4	5
m0	<p><b>TYPE OF MOTOR:</b></p> <p><b>00</b> non-FAAC operators. operators FAAC 412, 413/415, 770, 390.</p> <p><b>01</b> operators FAAC 391.</p> <p><b>02</b> operators FAAC S700H.</p> <p><b>03</b> operators FAAC 418</p> <p><b>04</b> operators FAAC S450H</p> <p><b>05</b></p> <p> <i>View only parameter, cannot be modified</i></p>	00	01	02	03	04	05
L0	<p><b>FUNCTION LOGICS:</b></p> <p><b>E</b> Semi-automatic.</p> <p><b>S</b> Semi-automatic "Step by step".</p> <p><b>S</b> "Safety devices" automatic.</p> <p><b>S</b> Automatic with in-pause reversing.</p> <p><b>S</b> "Step-by-step safety devices" automatic.</p> <p><b>A</b> Automatic 1.</p> <p><b>A</b> Automatic.</p> <p><b>A</b> Automatic "Step-by-step".</p> <p><b>A</b> Automatic with timer function.</p> <p><b>b</b> Semi-automatic "b".</p> <p><b>b</b> Mixed (OP at impulse/CL Dead-man).</p> <p><b>C</b> Dead-man.</p> <p><b>C</b> Custom.</p> <p> <i>Other more detailed programming possibilities are feasible by programming with a PC (see dedicated instructions).</i></p>	E	E	E	E	E	E

Display	Function	Default 0	Default 1	Default 2	Default 3	Default 4	Default 5
PA	<p><b>PAUSE TIME A:</b> Pause time following a <b>TOTAL</b> opening command. It has only effect if a logic with pause time was selected. Can be adjusted from 0 to 59 sec. in one-second steps. Next, the viewing changes in minutes and ten seconds (separated by a dot) and time is adjusted in 10-second steps, up to the maximum value of <b>9.5</b> minutes. E.g.: if the display shows <b>2.5</b>, the pause time will be 2 min. and 50 sec.</p> <p> <i>Other more detailed programming possibilities are feasible by programming with a PC (see dedicated instructions).</i></p>	20	20	20	20	20	20
Pb	<p><b>PAUSE TIME B:</b> Pause time following a <b>PARTIAL</b> opening command. It has only effect if a logic with pause time was selected. Can be adjusted from 0 to 59 sec. in one-second steps. Next, the viewing changes in minutes and ten seconds (separated by a dot) and time is adjusted in 10-second steps, up to the maximum value of <b>9.5</b> minutes. E.g.: if the display shows <b>2.5</b>, the pause time will be 2 min. and 50 sec.</p> <p> <i>Other more detailed programming possibilities are feasible by PC programming (see dedicated instructions).</i></p>	20	20	20	20	20	20
F1	<p><b>MOTOR 1 POWER:</b> Adjusts the maximum power level of motor 1.</p> <p><b>01</b> = minimum power <b>50</b> = maximum power</p> <p> <i>Other more detailed programming possibilities are feasible by programming with a PC (see dedicated instructions).</i></p> <p> <i>If the power value is changed, we advise you to execute a new SETUP.</i></p>	25	25	25	40	25	35
F2	<p><b>MOTOR 2 POWER:</b> Adjusts the maximum power level of motor 2.</p> <p><b>01</b> = minimum power <b>50</b> = maximum power</p> <p> <i>Other more detailed programming possibilities are feasible by programming with a PC (see dedicated instructions).</i></p> <p> <i>If the power value is changed, we advise you to execute a new SETUP.</i></p>	25	25	25	40	25	35
SP	<p><b>SPEED:</b> Adjusts the motion speed of the motors. There are 10 levels. The value is relative and not absolute, because the speed value refers to the weight of the leaf measured during the SETUP cycle</p> <p><b>01</b> = minimum speed <b>10</b> = maximum speed</p> <p> <i>Other more detailed programming possibilities are feasible by programming with a PC (see dedicated instructions).</i></p>	08	08	08	08	08	08



Display	Function	Default 0	Default 1	Default 2	Default 3	Default 4	Default 5
<b>rl</b>	<p><b>DECELERATION:</b> Adjusts deceleration space as a percentage of the total travel of the leaves. Adjustable from 00 to 99 % in 1% steps.</p> <p>00 = no deceleration 01 = minimum deceleration space 99 = maximum deceleration space</p> <p> <i>Other more detailed programming possibilities are feasible by PC programming (see dedicated instructions).</i></p>	30	30	30	20	20	20
<b>st</b>	<p><b>AUTOMATED SYSTEM STATUS:</b> Exit from programming, storage of data and return to the automated system status view</p> <p>00 = CLOSED 01 = OPEN 02 = Idle then "OPENS" 03 = Idle then "CLOSES" 04 = In "PAUSE" 05 = At opening stage 06 = At closing stage</p> <p>07 = FAIL SAFE in progress 08 = verification of BUS-2EASY devices in progress 09 = Pre-flashing then "OPENS" 10 = Pre-flashing then "CLOSES" 11 = Opening in EMERGENCY status 12 = Closing in EMERGENCY status</p>						





**2<sup>nd</sup> LEVEL PROGRAMMING**



To access 2<sup>ND</sup> LEVEL PROGRAMMING, press push-button **F** and, while holding it down, press push-button **+** :

- if you release the **+** key, the display shows the name of the first second level function (if the **dF** value persists, this means that programming was effected from the PC).
- if you also release the **F** push-button, the display shows the value of the function, which can be changed with keys **+** and **-**.
- if you press the **F** key (and hold it down), the display shows the name of the next function; if you release it, the values is shown and can be modified with keys **+** and **-**.
- when you reach the last function, press the **F** push-button to exit programming, and the display resumes showing the automated system status.

 **If programming via the PC with personalised password was effected, you CANNOT enter 2<sup>nd</sup> level programming.**





2 <sup>nd</sup> LEVEL PROGRAMMING  + 		Default 0	Default 1	Default 2	Default 3	Default 4	Default 5
<b>bo</b>	<p><b>MAXIMUM POWER AT THRUST:</b> The motors run at maximum power for the time set (ignoring the selected power level F1 and F2) during motion thrust. Adjustable from 00 to 06 seconds in 1-second steps.</p> <p> <i>Other more detailed programming possibilities are feasible by PC programming (see dedicated instructions).</i></p>	02	02	02	02	02	02
<b>el</b>	<p><b>ELECTRIC LOCK ON LEAF 2:</b> The board has a terminal dedicated to the connection of an electric lock. Normally the electric lock must be connected to leaf 1. If the electric lock is located on leaf 2, adjust the parameter.</p> <p>4 = electric lock on leaf 2 no = electric lock on leaf 1</p>	no	no	no	no	no	no
<b>cd</b>	<p><b>LEAF DELAY AT CLOSING:</b> Adjusts leaf delay at closing. Adjustable from 00 to 60 seconds in 1-second steps.</p> <p>00 = no delay 01 = minimum delay 60 = maximum delay</p>	05	05	05	05	05	05

Display	Function	Default 0	Default 1	Default 2	Default 3	Default 4	Default 5
od	<b>LEAF DELAY AT OPENING:</b> Opening of leaf 2 is delayed with respect to leaf 1, avoiding thus interferences between the leaves. y = active no = excluded	y	y	y	y	y	y
t	<b>WORK TIME (time-out):</b> We advise you to set a value longer than the time required by the gate to open and close completely. Can be adjusted from 01 to 59 sec. in 1 second steps. Next, the viewing changes in minutes and ten seconds (separated by a dot) and time is adjusted in 10 second steps, up to the maximum value of 9.5 minutes.	4.1	4.1	4.1	4.1	4.1	4.1
r8	<b>SPACE OF TRAVEL STOP SEARCH:</b> The set level, from 01 to 50, adjusts the space of the search for the travel stop referred to total travel of the leaves. For the default values 0-1-2-4, the value 50 corresponds to 40% of total travel, whereas for the default values 3-5, the value 50 corresponds to 20% of total travel. Leaves do not reverse in the space of the search for the travel stop in the event of an obstacle.	20	20	20	08	20	08
cs	<b>FINAL CLOSING THRUST:</b> The motors are run at maximum power to facilitate coupling with the electric lock (over pushing stroke). y = active no = excluded   <i>Other more detailed programming possibilities are feasible by programming with a PC (see dedicated instructions).</i>	no	no	no	no	no	no
rs	<b>REVERSING STROKE AT OPENING:</b> When the gate is closed before opening, the motors push to close to facilitate uncoupling the electric lock (reversing stroke). y = active no = excluded   <i>Other more detailed programming possibilities are feasible by programming with a PC (see dedicated instructions).</i>	no	no	no	no	no	no
SF	<b>SOFT TOUCH:</b> After touching the travel stop point, the leaves reverse and then rest gently. y = active no = excluded   <i>This function can be useful to respect the impact curve specified by current standards.</i>   <i>Other more detailed programming possibilities are feasible by PC programming (see dedicated instructions).</i>	no	no	no	no	no	no
PF	<b>PRE-FLASHING:</b> Enables you to select 5 types of pre-flashings of 3 sec. duration. no = no pre-flashing. OC = pre-flashing before every movement. CL = pre-flashing before a closing motion. OP = pre-flashing before an opening motion. PA = pre-flashing at end of pause only   <i>Other more detailed programming possibilities are feasible by programming with a PC (see dedicated instructions).</i>	no	no	no	no	no	no

Display	Function	Default 0	Default 1	Default 2	Default 3	Default 4	Default 5
FA	<p><b>TRAVEL-LIMIT STOP AT OPENING:</b></p> <p>The use of travel limit stops at opening enables us to indicate the point after which the equipment search for the mechanical stop point (01, 02, 03) or to immediately stop the automated system (04, 05, 06):</p> <p>00 = no travel limit device at opening for both leaves  01 = searches for stop point of leaf 1 and 2  02 = searches for stop point of leaf 1  03 = searches for stop point of leaf 2  04 = stops movement of leaf 1 and 2  05 = stops movement of leaf 1  06 = stops movement of leaf 2</p> <p> <i>By changing limit switches setting, the letters <b>50</b> together with the SETUP (DL18) LED flash on the display, to indicate that the SETUP must be executed when exiting the programming menu. If the limit switch is used, the SOFT-TOUCH function, if enabled, is not carried out.</i></p>	00	00	00	00	00	00
FC	<p><b>TRAVEL-LIMIT STOP AT CLOSING:</b></p> <p>The use of travel limit stops at closing enables us to indicate the point after which the equipment search for the mechanical stop point (01, 02, 03) or to immediately stop the automated system (04, 05, 06):</p> <p>00 = no travel limit device at closing for both leaves  01 = searches for stop point of leaf 1 and 2  02 = searches for stop point of leaf 1  03 = searches for stop point of leaf 2  04 = stops movement of leaf 1 and 2  05 = stops movement of leaf 1  06 = stops movement of leaf 2</p> <p> <i>By changing limit switches setting, the letters <b>50</b> together with the SETUP (DL18) LED flash on the display, to indicate that the SETUP must be executed when exiting the programming menu. If the limit switch is used, the SOFT-TOUCH function, if enabled, is not carried out.</i></p>	00	00	00	00	00	00
SE	<p><b>OBSTACLE SENSITIVITY:</b></p> <p>Change this parameter to set the time after which, in the event of an obstacle, the board commands leaf reversal, or leaf stop if the leaves are within the space for the travel limit search (see parameter r8).</p> <p>The fourth consecutive obstacle detected in the same direction is considered as the travel stop and the leaf stops in that position.</p> <p>01 = minimum sensitivity  10 = maximum sensitivity</p>	10	08	08	07	08	07
US	<p><b>ULTRA-SENSITIVITY:</b></p> <p>This function activates an obstacle detection system, based on the control of the variation of the current absorbed by the motor, causing immediate leaf reversal.</p> <p>y = active  no = excluded</p>	no	no	no	no	no	no

Display	Function	Default 0	Default 1	Default 2	Default 3	Default 4	Default 5
Ph	<p><b>CLOSING PHOTOCELLS:</b>                      Enable this function is you want the closing photocells to stop movement or reverse it at disengagement. If this function is excluded, normally the tripping of the photocells at closure causes the leaves to reverse immediately.</p> <p> <span style="color: red;">y</span> = reversal at disengagement  <span style="color: red;">no</span> = immediate reversal at opening</p>	no	no	no	no	no	no
Ad	<p><b>ADMAP FUNCTION:</b>                      This is used to activate operation according to French regulations NFP 25/362.</p> <p> <span style="color: red;">y</span> = active  <span style="color: red;">no</span> = excluded</p>	no	no	no	no	no	no
o1	<p><b>OUT 1:</b>                      Used for setting the OUT1 output (open collector N.O.):</p> <p> <span style="color: red;">00</span> = Always active  <span style="color: red;">01</span> = FAIL-SAFE  <span style="color: red;">02</span> = INDICATOR LIGHT (off when closed, lighted during opening and open/pause, flashes during closing)  <span style="color: red;">03</span> = COURTESY LIGHT (see next parameter)  <span style="color: red;">04</span> = ALARM on BATTERY operation  <span style="color: red;">05</span> = gate OPEN or in PAUSE  <span style="color: red;">06</span> = gate CLOSED  <span style="color: red;">07</span> = gate MOVING  <span style="color: red;">08</span> = gate in EMERGENCY status  <span style="color: red;">09</span> = gate OPENING  <span style="color: red;">10</span> = gate CLOSING  <span style="color: red;">11</span> = ELECTRIC LOCK command before CLOSURE (you have to interface with relay 24V – 100mA)  <span style="color: red;">12</span> = safety device ACTIVE  <span style="color: red;">13</span> = 'TRAFFIC LIGHTS' function (activates during OPENING and when gate OPEN)  <span style="color: red;">14</span> = timed output; it can be activated from the second radio channel OMNIDEC (see next parameter)  <span style="color: red;">15</span> = this output can be activated from the second radio channel OMNIDEC (step-by-step function)  <span style="color: red;">16</span> = electric lock before an OPENING (you have to interface with relay 24V – 100mA)</p> <p>  <i>Other more detailed programming possibilities are feasible by programming with a PC (see dedicated instructions).</i></p>	00	00	00	00	00	00
t1	<p><b>TIMING OUT 1 (only visible if at the previous step o1 the item 03-11-14 -16 was selected):</b></p> <p>Adjusts the timing of output OUT 1 if a timed function from 1 to 99 minutes in 1-minute step was selected for the functions 03-14 and from 1 to 99 seconds in 1-second step for the functions 11-16.</p>	02	02	02	02	02	02

Display	Fuction	Default 0	Default 1	Default 2	Default 3	Default 4	Default 5
02	<p><b>OUT 2:</b> Used for setting the OUT1 output (open collector N.O.):</p> <p>00 = Always active 01 = FAIL-SAFE 02 = INDICATOR LIGHT (off when closed, lighted during opening and open/pause, flashes during closing) 03 = COURTESY LIGHT (see next parameter) 04 = ALARM on BATTERY operation 05 = gate OPEN or in PAUSE 06 = gate CLOSED 07 = gate MOVING 08 = gate in EMERGENCY status 09 = gate OPENING 10 = gate CLOSING 11 = ELECTRIC LOCK command before CLOSURE (you have to interface with relay 24V – 100mA) 12 = safety device ACTIVE 13 = 'TRAFFIC LIGHTS' function (activates during OPENING and when gate OPEN) 14 = timed output; it can be activated from the second radio channel OMNIDEC (see next parameter) 15 = this output can be activated from the second radio channel OMNIDEC (step-by-step function) 16 = electric lock before an OPENING (you have to interface with relay 24V – 100mA)</p> <p> <i>Other more detailed programming possibilities are feasible by programming with a PC (see dedicated instructions).</i></p>	02	02	02	02	02	02
t2	<p><b>TIMING OUT 2 (only visible if at the previous step 02 the item 03-11-14 -16 was selected):</b></p> <p>Adjusts the timing of output OUT 2 if a timed function from 1 to 99 minutes in 1-minute step was selected for the functions 03-14 and from 1 to 99 seconds in 1-second step for the functions 11-16.</p>	02	02	02	02	02	02
X	<p><b>RESET and X-COM RADIO MODULE ACQUISITION:</b></p> <p>The X-COM module is used for radio communication between board and PC. Before enabling a communication, the X-COM module must be configured.</p> <p>If no is displayed when entering this menu, this means that the X-COM module has not yet been configured or fitted. To start the configuration procedure, fit the module in the M1A-XCOM connector on the board and hold down push-button + for 5 sec. 4 will appear on the display and the flashing light will operate. The configuration procedure must then be terminated from the PC. If 4 is shown when you enter this menu, this means that the X-COM module has been configured and is ready to communicate. The X-COM module can be reset by holding down the – key for 5 seconds.</p> <p>4 = X-COM module enabled to function. no = no X-COM module fitted or configured.</p>	no	no	no	no	no	no

Display	Function	Default 0	Default 1	Default 2	Default 3	Default 4	Default 5
AS	<p><b>ASSISTANCE REQUEST – CYCLES COUNTER (coupled to the next two functions):</b></p> <p><b>Y</b> = When the number of cycles settable with the following <b>nc</b> and <b>nd</b> functions is reached, this facility pre-flashes for 8 sec. (in addition to the pre-flashing already set with the <b>PF</b> function) before every movement.</p> <p> <i>If, from the PC, an assistance request is set, with a number of cycles greater than 99.990, the next two functions <b>nc</b> and <b>nd</b> will respectively show 99 and 99.</i></p> <p><b>no</b> = the following functions <b>nc</b> and <b>nd</b> indicate how many cycles the system effected up to a maximum displayable amount of 99.990.</p> <p> <i>If the number of effected cycles is greater than 99.990, the next two functions <b>nc</b> and <b>nd</b> will respectively show 99 and 99.</i></p> <p>This function can be useful to set routine maintenance or to check the effected work cycles.</p>	no	no	no	no	no	no
nc	<p><b>CYCLE PROGRAMMING (THOUSANDS):</b></p> <p>If <b>AS</b> = <b>Y</b>, the display indicates the number of the thousands of cycles after which assistance is requested (settable from <b>0</b> to <b>99</b>).</p> <p>If <b>AS</b> = <b>no</b>, the display indicates the number of the thousands of effected cycles. The displayed value updates itself as the cycles follow, interacting with the <b>nd</b> values.</p> <p> <i>If <b>AS</b> = <b>no</b> by pressing keys + and - for 5 sec., the cycles counter is reset.</i></p>	00	00	00	00	00	00
nd	<p><b>CYCLE PROGRAMMING (TENS):</b></p> <p>If <b>AS</b> = <b>Y</b>, the display indicates the number of tens of cycles after which assistance is requested (settable from <b>0</b> to <b>99</b>).</p> <p>If <b>AS</b> = <b>no</b>, the display indicates the number of the tens of effected cycles. The displayed value updates itself as the cycles follow, interacting with the <b>nc</b> values.</p> <p> <i>Example: If the system has performed 11.218, <b>nc</b> = 11 and <b>nd</b> = 21 will be shown</i></p>	00	00	00	00	00	00
M1	<p><b>MOTOR 1 DRIVE (dead-man function)</b></p> <p>Hold down push-button + opening <b>oP</b> Hold down push-button - closing <b>cl</b></p>	--	--	--	--	--	--
M2	<p><b>MOTOR 2 DRIVE (dead-man function)</b></p> <p>Hold down push-button + opening <b>oP</b> Hold down push-button - closing <b>cl</b></p>	--	--	--	--	--	--
St	<p><b>AUTOMATED SYSTEM STATUS:</b></p> <p>Exit from programming, storage of data and return to the automated system status view.</p> <p>00 = CLOSED 01 = OPEN 02 = Idle then "OPENS" 03 = Idle then "CLOSES" 04 = In "PAUSE" 05 = At opening stage 06 = At closing stage</p> <p>07 = FAIL SAFE in progress 08 = verification of BUS-2EASY devices in progress 09 = Pre-flashing then "OPENS" 10 = Pre-flashing then "CLOSES" 11 = Opening in EMERGENCY status 12 = Closing in EMERGENCY status</p>						

**TIME LEARNING - SETUP**

The opening and closing time is determined by a time learning procedure (SETUP).

 This procedure is the same for all selectable defaults.

When the encoders (J3 or J7) are connected to the relevant inputs, the board automatically recognises the presence of these accessories.

 By powering up the board if a SETUP was never executed, or if the board requests it, the letters **50** together with the SETUP (DL18) LED flash on the display, to indicate that the SETUP must be executed.

 Before performing the set-up phase, select the type of motors used.

 When the SETUP procedure has been started, if the leaves at point 2 and 3 open instead of closing, the motor power supply cables must be changed over.

To execute time learning, follow the steps below:

1. **Take the leaves to halfway their travel (very important for a successful SETUP).**
2. Hold down the SETUP (SW3) push-button, until the SETUP (DL18) LED goes OFF and leaf 2 (if present) begins the slowed down closing movement, stopping when it reaches the mechanical stop point. At this stage, **51** flashes on the display (setup: FIRST CLOSURE LEAF 2)
3. Leaf 1 starts the slowed down closing movement, stopping when it reaches the closing mechanical stop. At this stage, **52** flashes on the display (setup: FIRST CLOSURE LEAF 1)
4. Leaf 1 begins the slowed down opening movement, followed by leaf 2 (if present) also slowed down. At this stage, **54** flashes on the display (setup: OPEN)
5. When the opening mechanical stop point is reached, both leaves stop and leaf 2 (if present) automatically restarts to close at full speed, followed by leaf 1. At this stage, **55** flashes on the display (setup: FAST CLOSE).
6. When the closing mechanical stop point is reached, both leaves stop and leaf 1 restarts to open automatically at full speed followed by leaf 2 (if present). At this stage, **56** flashes on the display (setup: FAST OPEN).
7. If an automatic logic was selected, the board counts the set pause and automatically closes the gate. Otherwise, give an OPEN pulse to close the gate.

**AUTOMATED SYSTEM TEST**

When you have finished installation and programming, check if the system is operating correctly. In particular check if the safety devices intervene correctly, and make sure that the system satisfies current safety regulations. Close the cover in its seat with a seal.

Next, tighten the four supplied screws to guarantee the degree of protection against external agents .



**ALARM AND ERROR SIGNALS**

If **alarms** (conditions not prejudicing gate operation) or **errors** (conditions preventing the gate from operating), the display shows the number referring to the condition.

 These signals will disappear during the following cycle only if the cause is removed.

**ALARMS**

 When an ALARM occurs, LED DL20 starts to flash. If you simultaneously press keys + and - the display will show the number of the fault in progress

All the alarms shown on the display are indicated in Tab.1.

**Tab. 1 - Alarms**

20	Obstacle on MOTOR 1
21	Obstacle on MOTOR 2
22	MOTOR 1 current limited
23	MOTOR 2 current limited
24	LAMP output short circuited
25	LOCK output short circuited
30	radio codes XF memory full
35	Timer function active
40	Service request
45	Battery operation
50	HOLD CLOSE function in operation (activated by PC)

**ERRORS**

 When an ERROR occurs, LED DL20 goes ON at steady beam. If you simultaneously press keys + and - the display will show the number of the fault in progress

All the errors shown on the display are indicated in Tab.2.

**Tab. 2 - Errors**

01	Board failure
02	Thermal protection active (wait for reset)
03	Motor 1 failure
04	Motor 2 failure
08	BUS2EASY device error
10	Motor 1 limit switch error
11	Motor 2 limit switch error
15	Time-out elapsed
17	Motor 1 encoder faulty
18	Motor 2 encoder faulty
19	Incorrect memory data