

# C720

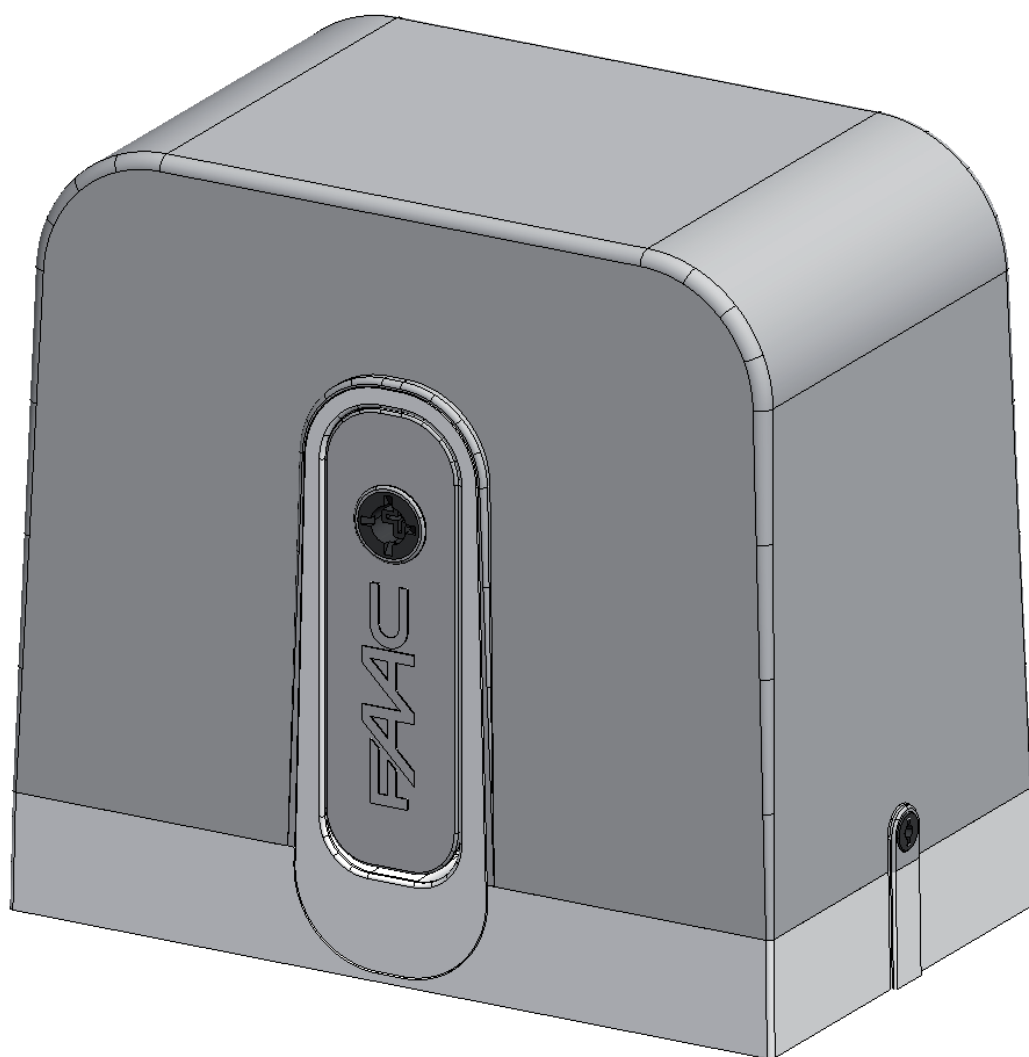

# FAAC

## EC DECLARATION OF CONFORMITY FOR MACHINES

(DIRECTIVE 2006/42/EC)

**Manufacturer:** FAAC S.p.A.

**Address:** Via Benini, 1 - 40069 Zola Predosa BOLOGNA - ITALY

**Declares that:** Operator mod. C720

is built to be integrated into a machine or to be assembled with other machinery to create a machine under the provisions of Directive 98/37/EC;

conforms to the essential safety requirements of the following EEC directives:

2006/95/EC Low Voltage Directive

2004/108/EC Electromagnetic Compatibility Directive

and also declares that it is prohibited to put into service the machinery until the machine in which it will be integrated or of which it will become a component has been identified and declared as conforming to the conditions of Directive 2006/42/EEC and subsequent amendments.

Bologna, 01-11-2008

The Managing Director

A. Marcellan



## WARNINGS FOR THE INSTALLER

### GENERAL SAFETY OBLIGATIONS

- 1) **ATTENTION! To ensure the safety of people, it is important that you read all the following instructions. Incorrect installation or incorrect use of the product could cause serious harm to people.**
- 2) Carefully read the instructions before beginning to install the product.
- 3) Do not leave packing materials (plastic, polystyrene, etc.) within reach of children as such materials are potential sources of danger.
- 4) Store these instructions for future reference.
- 5) This product was designed and built strictly for the use indicated in this documentation. Any other use, not expressly indicated here, could compromise the good condition/operation of the product and/or be a source of danger.
- 6) FAAC declines all liability caused by improper use or use other than that for which the automated system was intended.
- 7) Do not install the equipment in an explosive atmosphere: the presence of inflammable gas or fumes is a serious danger to safety.
- 8) The mechanical parts must conform to the provisions of Standards EN 12604 and EN 12605.  
For non-EU countries, to obtain an adequate level of safety, the Standards mentioned above must be observed, in addition to national legal regulations.
- 9) FAAC is not responsible for failure to observe Good Technique in the construction of the closing elements to be motorised, or for any deformation that may occur during use.
- 10) The installation must conform to Standards EN 12453 and EN 12445.  
For non-EU countries, to obtain an adequate level of safety, the Standards mentioned above must be observed, in addition to national legal regulations.
- 11) Before attempting any job on the system, cut out electrical power.
- 12) The mains power supply of the automated system must be fitted with an all-pole switch with contact opening distance of 3 mm or greater. Use of a 6A thermal breaker with all-pole circuit break is recommended.
- 13) Make sure that a differential switch with threshold of 0.03 A is fitted upstream of the system.
- 14) Make sure that the earthing system is perfectly constructed and connect metal parts of the closure to it.
- 15) The automated system is supplied with an intrinsic anti-crushing safety device consisting of a torque control. Nevertheless, its tripping threshold must be checked as specified in the Standards indicated at point 10.
- 16) The safety devices (EN 12978 standard) protect any danger areas against **mechanical movement Risks**, such as crushing, dragging, and shearing.
- 17) Use of at least one indicator-light (e.g. FAACLIGHT ) is recommended for every system, as well as a warning sign adequately secured to the frame structure, in addition to the devices mentioned at point "16".
- 18) FAAC declines all liability as concerns safety and efficient operation of the automated system, if system components not produced by FAAC are used.
- 19) For maintenance, strictly use original parts by FAAC.
- 20) Do not in any way modify the components of the automated system.
- 21) The installer shall supply all information concerning manual operation of the system in case of an emergency and shall hand over to the user the warnings handbook supplied with the product.
- 22) Do not allow children or adults to stay near the product while it is operating.
- 23) Keep remote controls or other pulse generators away from children, to prevent the automated system from being activated involuntarily.
- 24) Transit is permitted only when the automated system is idle.
- 25) The user must not attempt any kind of repair or direct action whatever and contact qualified personnel only.
- 26) Check at least every 6 months the efficiency of the system, particularly the efficiency of the safety devices (including, where foreseen, the operator thrust force) and of the release devices.
- 27) **Anything not expressly specified in these instructions is not permitted.**

**CONTENTS**

**1 GENERAL REMARKS ..... 3**

**2 DESCRIPTION AND TECHNICAL SPECIFICATIONS ..... 3**

**3 DIMENSIONS ..... 4**

**4 ELECTRIC EQUIPMENT (standard system)..... 4**

**5 INSTALLATION OF AUTOMATED SYSTEM ..... 4**

**5.1 PRELIMINARY CHECKS..... 4**

**5.2 MASONRY FOR FOUNDATION PLATE ..... 5**

**5.3 MECHANICAL INSTALLATION ..... 6**

**5.4 INSTALLING THE RACK..... 7**

**5.4.1 STEEL RACK TO WELD (Fig.11) ..... 7**

**5.4.3 NYLON RACK TO SCREW (Fig. 13) ..... 7**

**5.4.2 STEEL RACK TO SCREW (Fig. 12) ..... 7**

**6 OPERATIONAL START-UP ..... 8**

**6.1 ELECTRONIC BOARD CONNECTION ..... 8**

**6.1.1 EARTHING ..... 8**

**6.1.2 ELECTRONIC EQUIPMENT ..... 8**

**6.2 POSITIONING OF LIMIT SWITCHES ..... 9**

**7 TESTING THE AUTOMATED SYSTEM ..... 9**

**8 OPERATOR RELEASE/LOCK ..... 9**

**9 MAINTENANCE ..... 10**

**10 REPAIR ..... 10**

**11 ACCESSORIES ..... 10**

**11.1 BATTERY KIT ..... 10**

**11.2 RADIO MODULE ..... 10**

**11.3 MOTOR LOCK RELEASE BATTERIES ..... 10**

# C720

Thank you for choosing to buy this product. We are sure it will meet your needs in full provided it is used for the purposes for which it has been designed.

**This product was designed and built to control vehicle access. AVOID USING IT FOR ANY OTHER PURPOSE.**



**Read this manual provided with the product carefully because it provides important information on safety, installation, use and maintenance.**

## 1 GENERAL REMARKS

These instructions apply to the following models:

### C720

Model C720 is an electromechanical operator designed to move sliding gates.

A practical and functional mechanical lock that acts directly on the motor ensures the gate is locked when the operator is not working and, therefore, no electric lock needs to be installed.

A convenient manual release device allows the gate to be manoeuvred in the event of a power cut, if emergency batteries are not installed or if the operator is not in service.

## 2 DESCRIPTION AND TECHNICAL SPECIFICATIONS

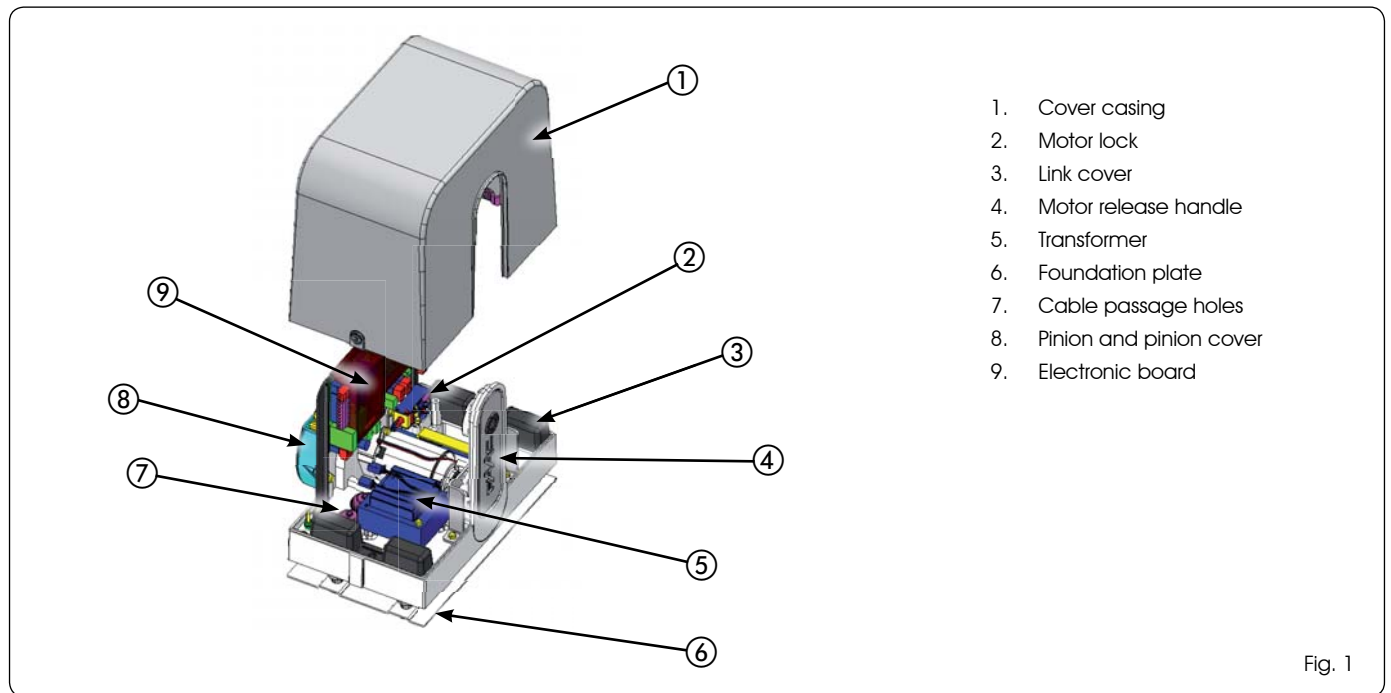

MODEL	C720
Power supply	230 V~ 50 Hz
Max. Absorbed power (W)	170
Thrust on pinion (N)	320
Max. Torque (Nm)	18
Type of pinion	Z28 module 4
Gate max. recommended length (m)	15
Max. leaf weight (Kg)	400
Gate speed (m/min)	min. 8 Max. 18
Limit switch type	Magnetic
Clutch	Electronic

Operating temperature (°C)	-20 +55
Gearmotor weight (kg)	6
Protection level	IP44
Gearmotor dimensions	See Fig.02
Use frequency	RESIDENTIAL

**3 DIMENSIONS**

Dimensions in mm

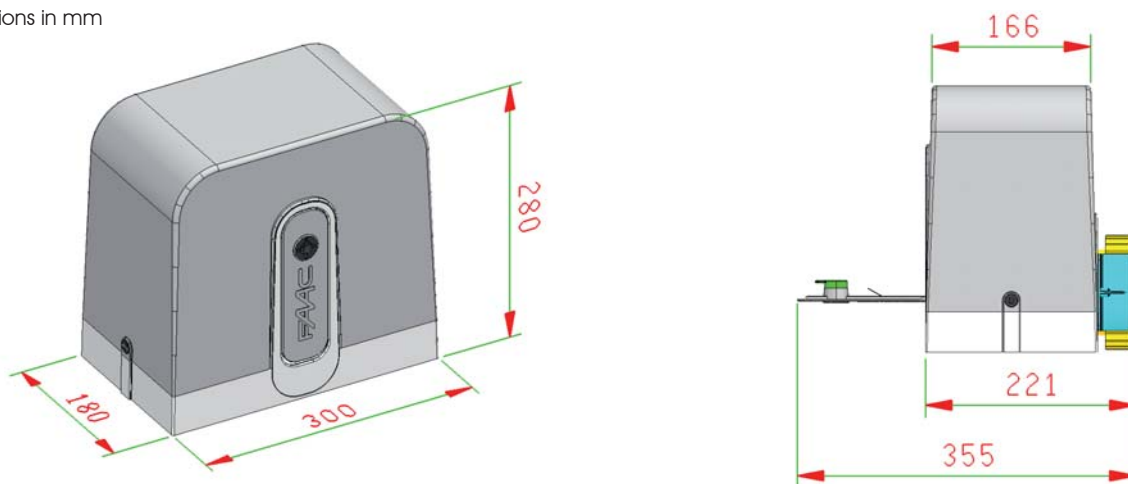

Fig. 2

**4 ELECTRIC EQUIPMENT (standard system)**

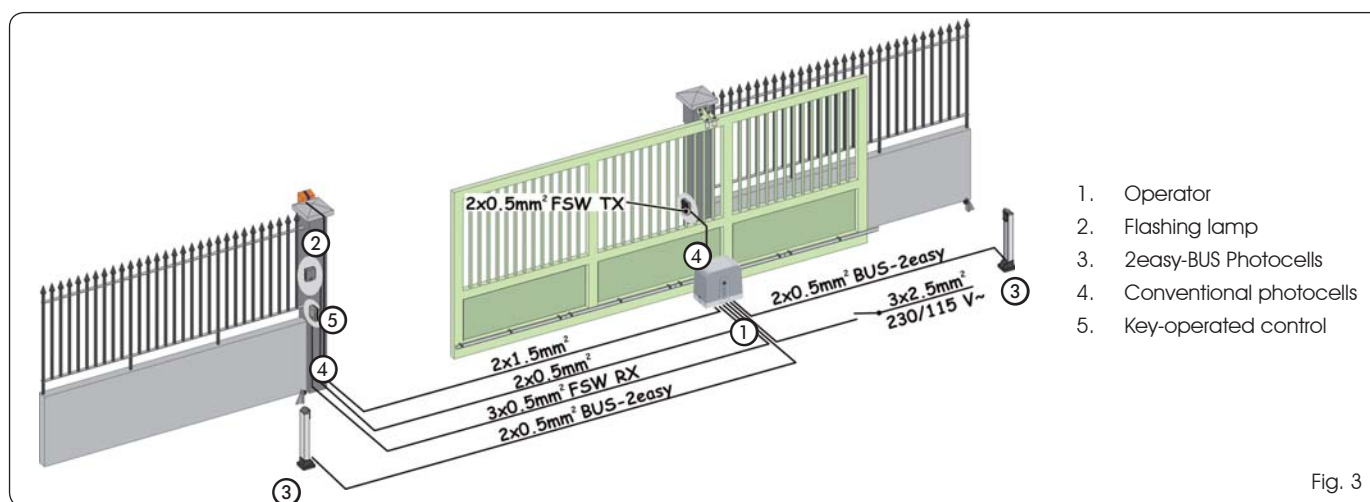

Fig. 3

**5 INSTALLATION OF AUTOMATED SYSTEM**

**5.1 PRELIMINARY CHECKS**

To ensure safety and an efficiently operating automated system, make sure the following conditions are observed:

- The gate structure must be suitable for automation. The following are necessary in particular: wheel diameter must be in proportion to the weight of the gate to be automated, an upper guide must be provided, plus mechanical limit switches to prevent the gate derailing.
- The gate slide track must be linear and horizontal.
- Manual movement of the gate must be easy throughout its travel.
- The soil must permit sufficient stability for the foundation plinth.
- There must be no pipes or electric cables in the plinth excavation area.
- If the gearmotor is exposed to passing vehicles, install, if possible, adequate means of protection against accidental impact.
- Check if an efficient earthing is available for connection to the gearmotor.

If the elements checked do not meet the above requirements, arrange to ensure their compliance.

**5.2 MASONRY FOR FOUNDATION PLATE**

1. Assemble the foundation plate as shown in Fig. 4.
2. The foundation plate must be located as shown in Fig. 5 (right closing) or Fig. 6 (left closing) to ensure the rack and pinion mesh correctly.

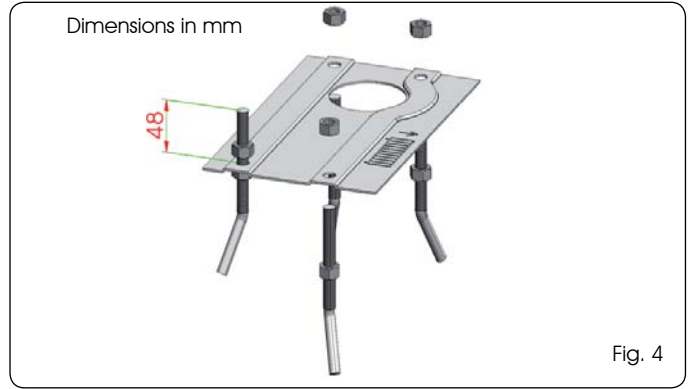

Fig. 4

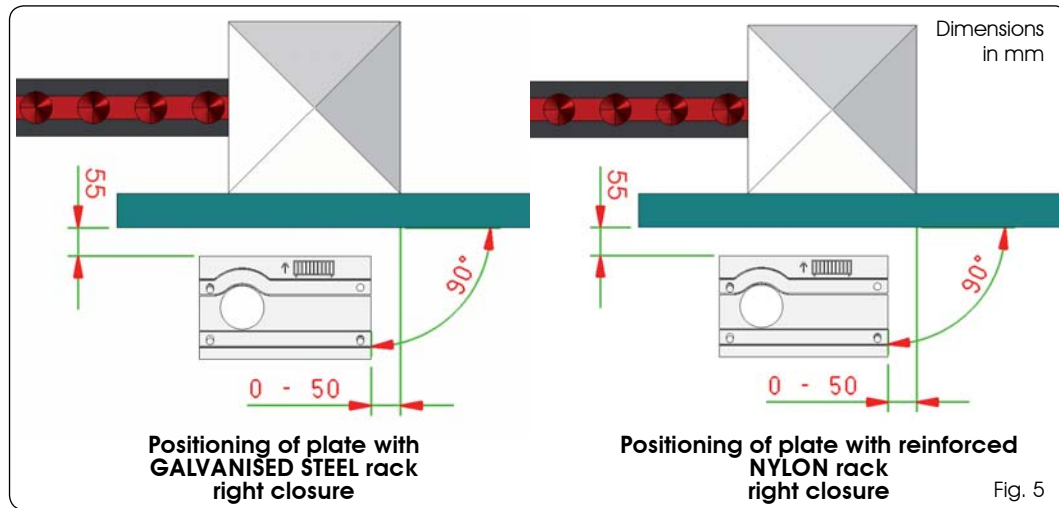

Fig. 5

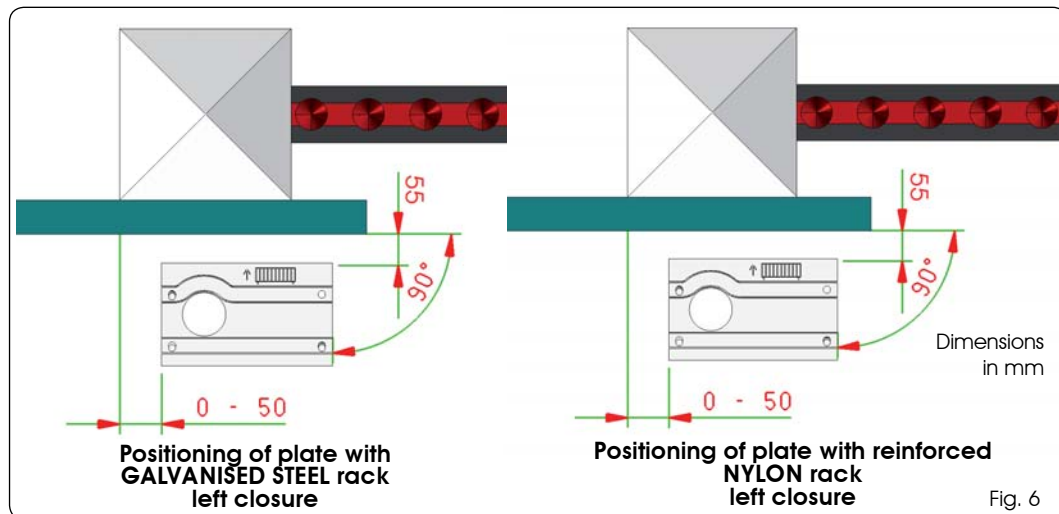
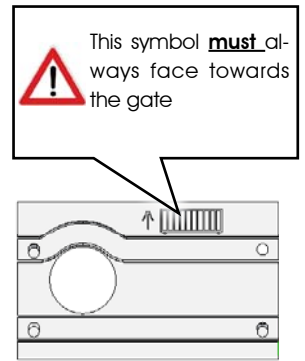

Fig. 6

3. Prepare a foundation plinth as shown in Fig. 7 and wall in the foundation plate, supplying one or more sheaths for routing electric cables through the hole in the foundation plate.

**Using a spirit level, check if the plate is perfectly level.**

Wait for the cement to set.

4. Lay the electric cables for connection to the accessories and power supply as shown in Fig. 3.

**To facilitate the connections in the control unit, pull out the leads by at least 30 cm from the hole on the plate.**

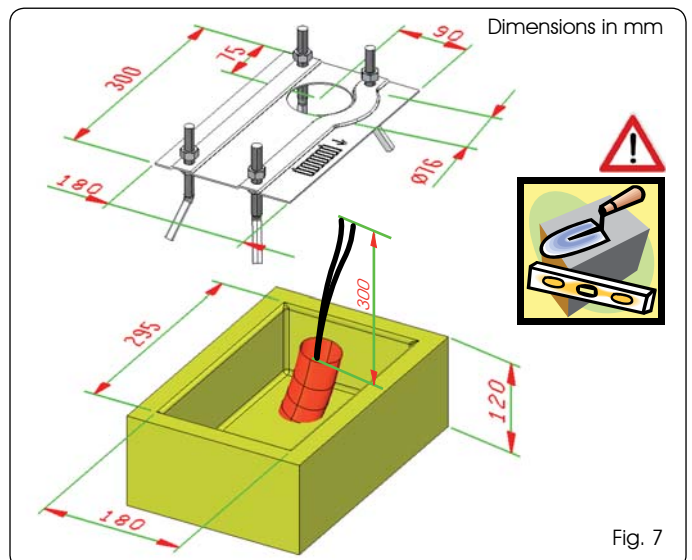

Fig. 7

**5.3 MECHANICAL INSTALLATION**

1. Remove the cover case by turning the clips through 90° and raising the cover (Fig. 8).
2. Position the operator on the foundation plate using the nuts and washers provided as shown in Fig. 9. During this operation, pass the cables through openings in the motor casing (see Fig. 9 re. ①).

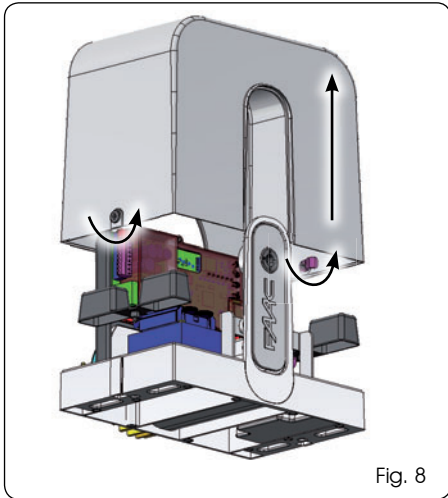

Fig. 8

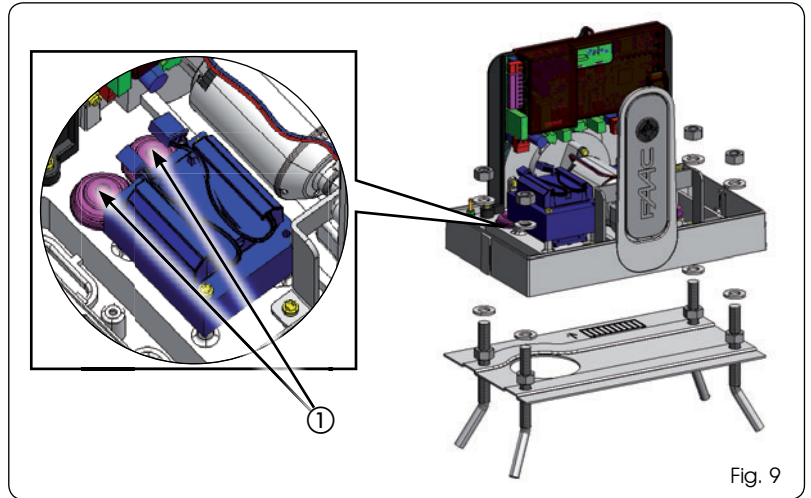
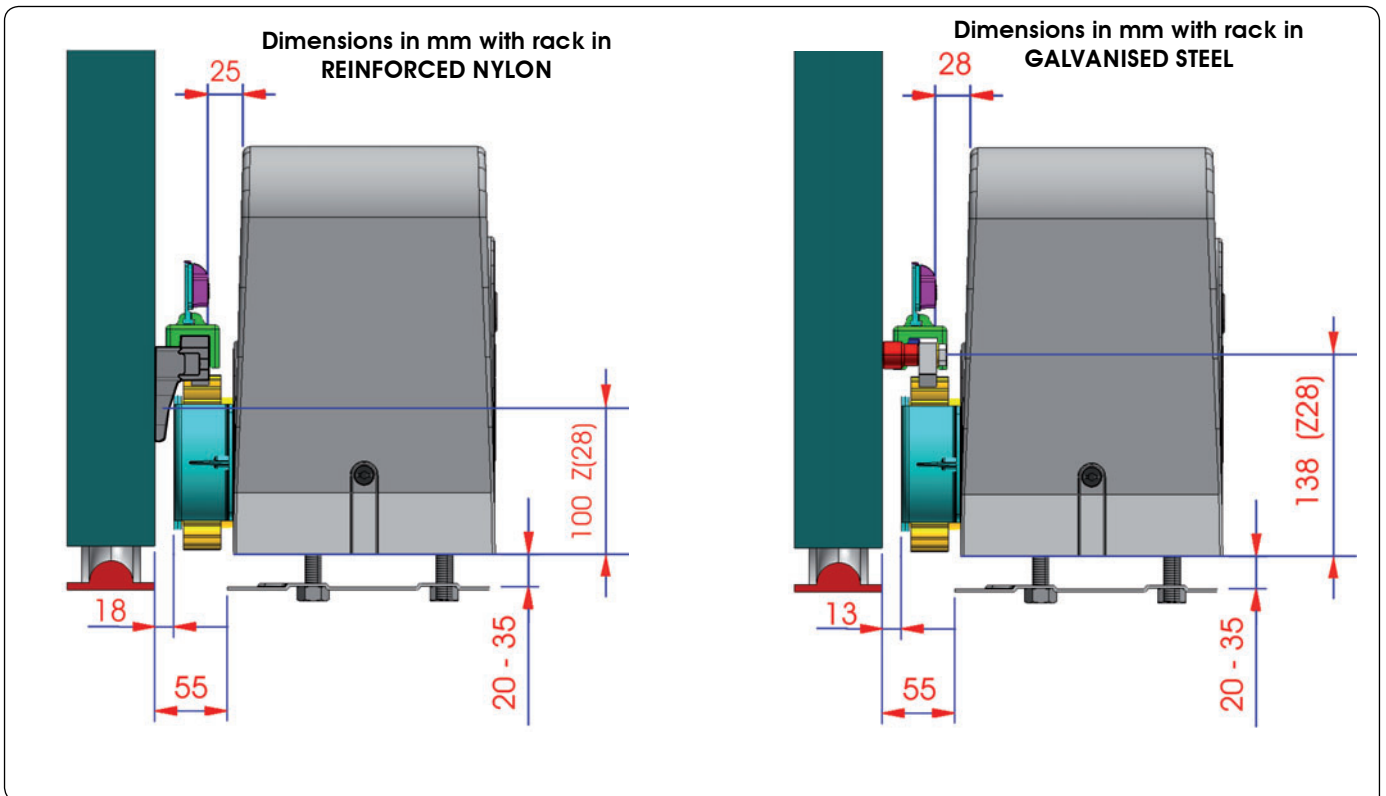

Fig. 9

3. Adjust the height of the gearmotor and the distance from the gate with reference to the dimensions in Fig. 10.



**Operation required for correct fastening of the rack and to keep open the option of new adjustments.**



4. Secure the gearmotor to the plate by tightening the fastening nuts.
5. Prepare the gearmotor for manual operating mode as described in paragraph 8.



**Make sure that the gate, or parts of it, doesn't touch the pinion support during the whole movement.**

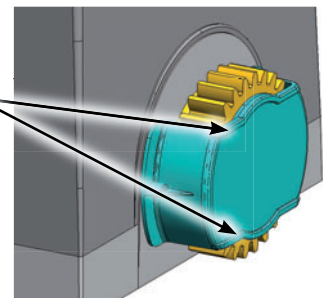

Fig. 10

**5.4 INSTALLING THE RACK**

**5.4.1 STEEL RACK TO WELD (Fig. 11)**

1. Place the three threaded pawls on the rack element, positioning them at the top of the slot. In this way, the slot play will enable any adjustments to be made.
2. Manually take the leaf into its closing position.
3. Lay the first piece of rack level on the pinion and weld the threaded pawl on the gate as shown in Fig. 14.
4. Move the gate manually, checking if the rack is resting on the pinion, and weld the second and third pawls.
5. Bring another rack element near to the previous one, using a piece of rack (as shown in Fig. 15), to synchronise the teeth of the two elements.
6. Move the gate manually and weld the three threaded pawls, thus proceeding until the gate is fully covered.

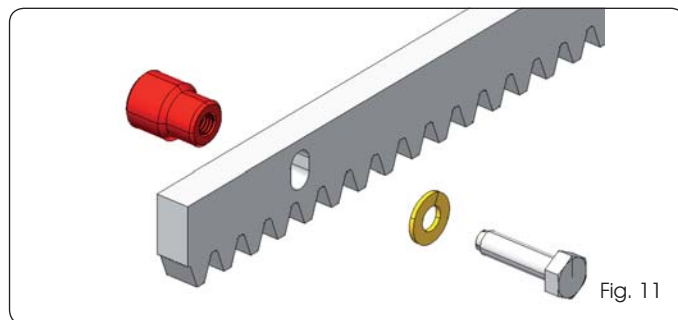

Fig. 11

**5.4.2 STEEL RACK TO SCREW (Fig. 12)**

1. Manually take the leaf into its closing position.
2. Lay the first piece of rack level on the pinion and place the spacer between the rack and the gate, positioning it at the top of the slot. In this way, the slot play will enable any adjustments to be made.
3. Mark the drilling point on the gate. Drill a  $\varnothing$  6.5 mm hole and apply thread with a  $\varnothing$  8 mm male tap. Screw the bolt.
4. Move the gate manually, checking if the rack is resting on the pinion, and repeat the operations at point 3.
5. Bring another rack element near to the previous one, using a piece of rack (as shown in figure 15) to synchronise the teeth of the two elements.
6. Move the gate manually and carry out the securing operations as for the first element, thus proceeding until the gate is fully covered.

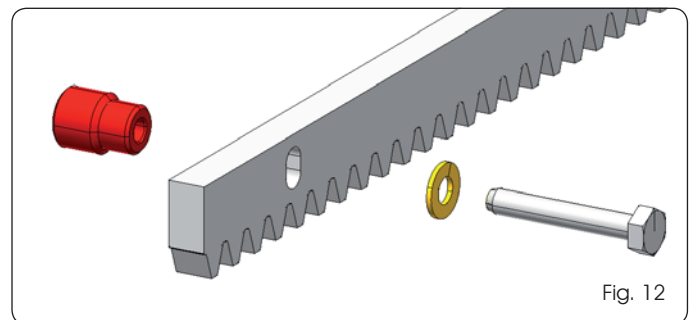

Fig. 12

**5.4.3 NYLON RACK TO SCREW (Fig. 13)**

1. Manually take the leaf into its closing position.
2. Lay the first piece of the rack level on the pinion and mark the drilling point on the gate; drill  $\varnothing$  6.5 mm and screw in the self-tapping screw provided with its reinforcing plate.
3. Move the gate manually, checking if the rack is resting on the pinion, and repeat the operations at point 2.
4. Couple another rack element and fit to the previous element.
5. Move the gate manually and carry out the securing operations as for the first element, thus proceeding until the gate is fully covered.

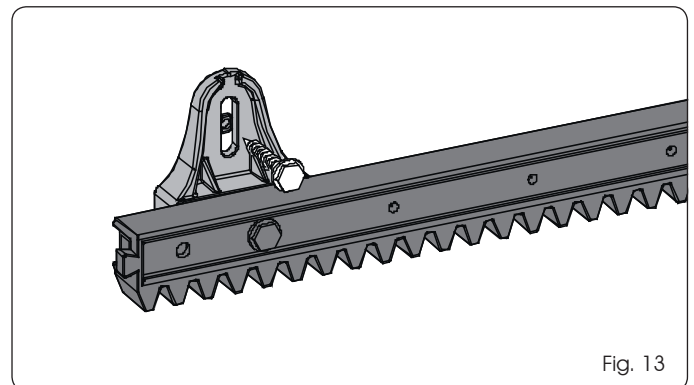

Fig. 13

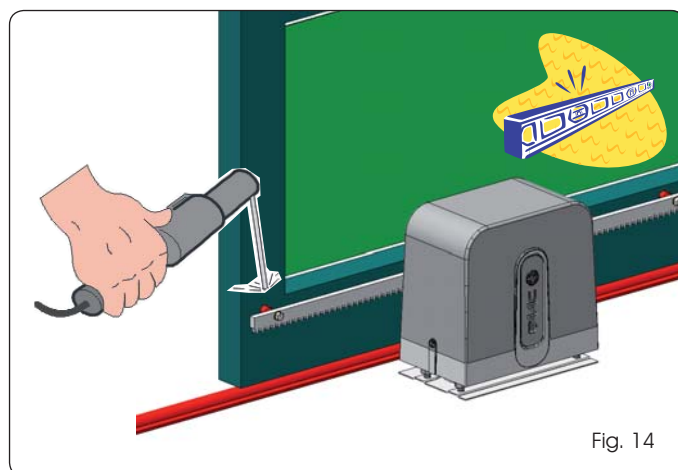

Fig. 14

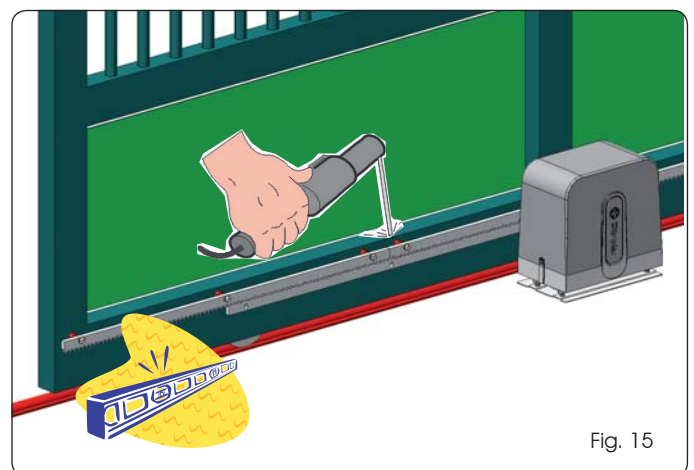





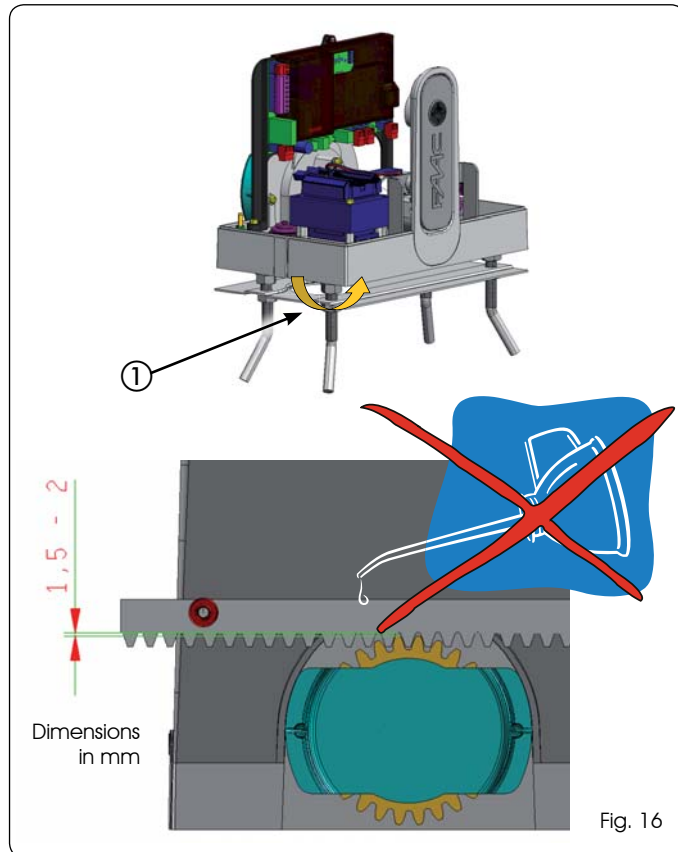

Fig. 15

**Important notes on rack installation:**

-  **Make sure that, during the gate travel, all the rack elements do not exit the pinion.**
-  **Do not, on any account, weld the rack elements either to the spacers or to each other.**
-  **When the rack has been installed, to ensure it meshes correctly with the pinion, we advise you to lower the gearmotor position by about 1.5 - 2 mm by adjusting the nuts (Fig.16 re. ①).**
-  **Do not use grease or other lubricants between rack and pinion (Fig. 16)**
-  **Manually check if the gate regularly reaches the mechanical limit switches and make sure there is no friction during gate travel.**



**6 OPERATIONAL START-UP**

**6.1 ELECTRONIC BOARD CONNECTION**



**Before attempting any work on the control board (connections, programming, maintenance), always turn off power.**



- Observe points 10, 11, 12, 13, 14 of the GENERAL SAFETY OBLIGATIONS.
- Follow the instructions in Fig. 3 to arrange the cables in the ducts and make the electrical connections with the selected accessories.
- Always separate power cables from control and safety cables (push-button, receiver, photocells, etc.).
- Use separate sheaths in order to avoid any electrical interference.

**6.1.1 EARTHING**

Connect the earth cable as described in Fig.17.

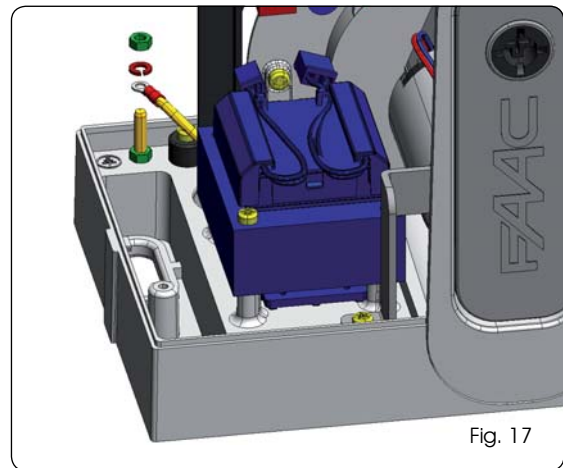

**6.1.2 ELECTRONIC EQUIPMENT**

The electronic control equipment in the gearmotors is fastened to a mount (Fig. 18 re. ①) with a clear cover (Fig. 18 re. ②). The board programming buttons are positioned on the cover (Fig.18 re. ③) and this makes it possible to programme the board without having to remove the cover.

 **To connect and program the control unit correctly, observe the specific instructions.**

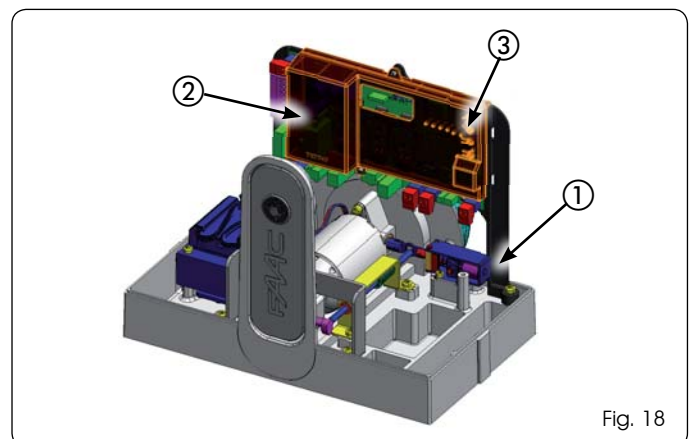

## 6.2 POSITIONING OF LIMIT SWITCHES



To ensure correct positioning of the limit switch magnets, the control unit must be installed and correctly connected with all control and safety accessories .

The operator is equipped with a magnetic limit switch sensor built directly into the electronic control board.

The gate is stopped, during opening or closure, at the moment when the polarised magnet secured to the upper part of the rack activates the sensor.

Assemble both magnets as shown in Fig. 19.

Prepare the operator for manual operating mode as described in chapter 8 and power the system.

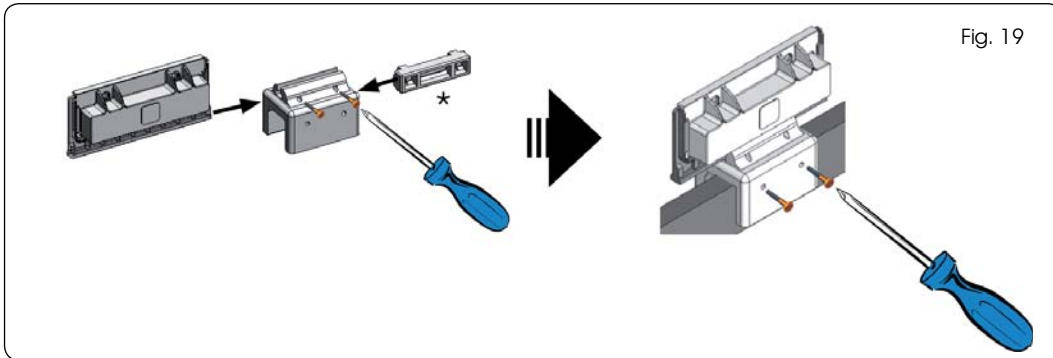

Fig. 19

To position the limit switch on the rack, refer to the electronic equipment instructions.

To avoid damage to the operator and/or interruptions in the operation of the automated system, approximately 40 mm must be left from the mechanical limit switches.

## 7 TESTING THE AUTOMATED SYSTEM

Once the operator has been installed, carry out a thorough operational check of all accessories and connected safety devices.

Press-fit the plastic covers of the operator fastening bolts, ensuring that the arrow is facing the gate (Fig. 20 re. ①), insert the cover casing (Fig. 20 re. ②) and turn the side clips (Fig. 20 re. ③).

Give the Customer the "User Guide" and explain the correct operation and use of the gearmotor, highlighting potential high-risk areas of the automated system.

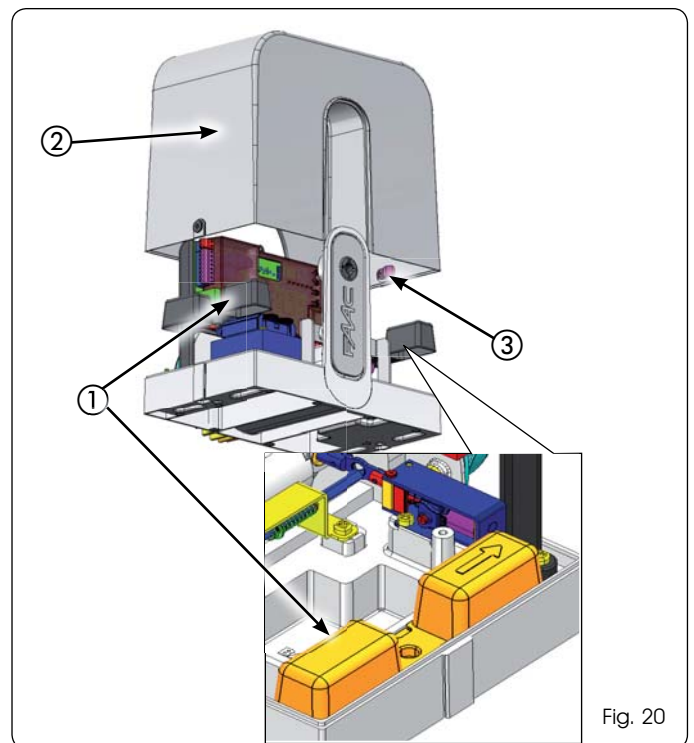

Fig. 20

## 8 OPERATOR RELEASE/LOCK



During the release/lock manoeuvre, take care to prevent an involuntary pulse from operating the gate.

Proceed as follows to release the gearmotor:

1. Turn the release clockwise as shown in Fig. 21 re. ①. The release lever will move slightly away from the operator body (Fig. 21 re. ②)
2. Fully lower the release lever to the mechanical stop Fig. 21 re. ③.
3. Carry out the opening or closing manoeuvre manually.

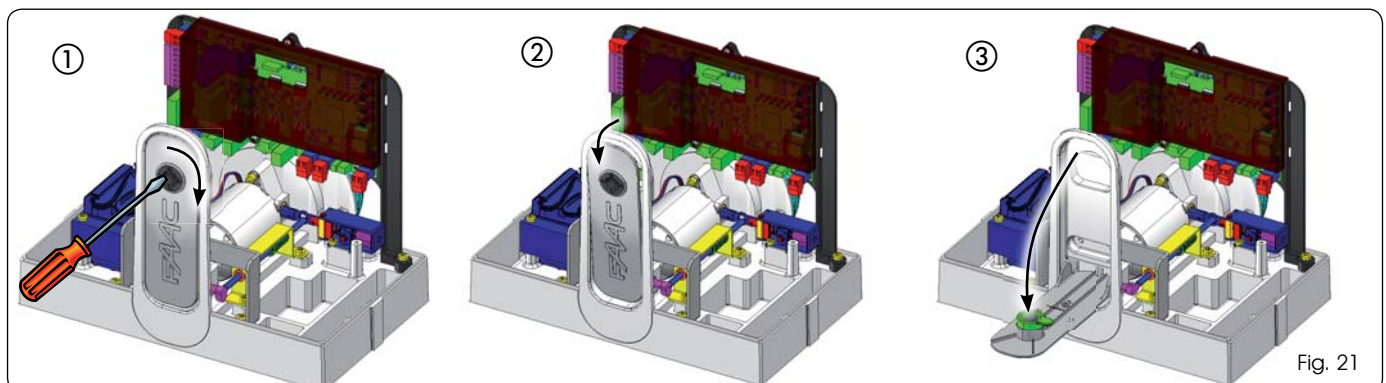



Fig. 21

Proceed as follows to lock the gearmotor:

1. Fully raise the release lever to the mechanical stop, Fig. 22 re. ①.
2. Turn the release anticlockwise as shown in Fig. 22 re. ②.

 **To maintain the operator intact, avoid pulsing the gate to operate before resetting the lock system.**

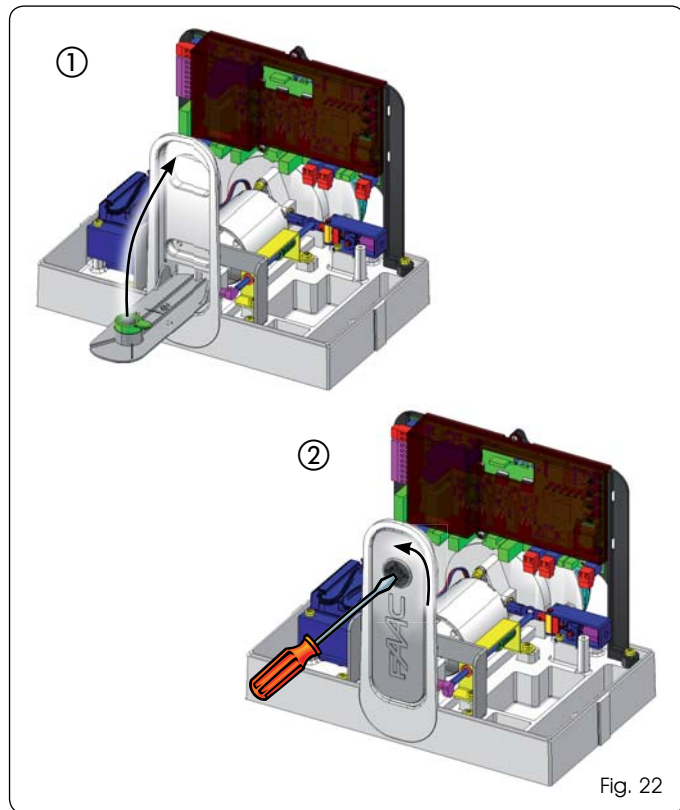

Fig. 22

## 9 MAINTENANCE

It is advisable to check the efficiency of the system at least every 6 months, particularly the efficiency of the safety devices (including the motor thrust force, which must comply with current standards) and of the release devices.

## 10 REPAIR

Contact an authorised Repair Centre for repairs.

## 11 ACCESSORIES

### 11.1 BATTERY KIT

Install the battery kit as shown in Fig. 23, inserting it in its seat and securing with screw re. ①. Connect it to the appropriate connector on the board (see relevant instructions).

Refer to the specific instructions for all information on the battery kit.

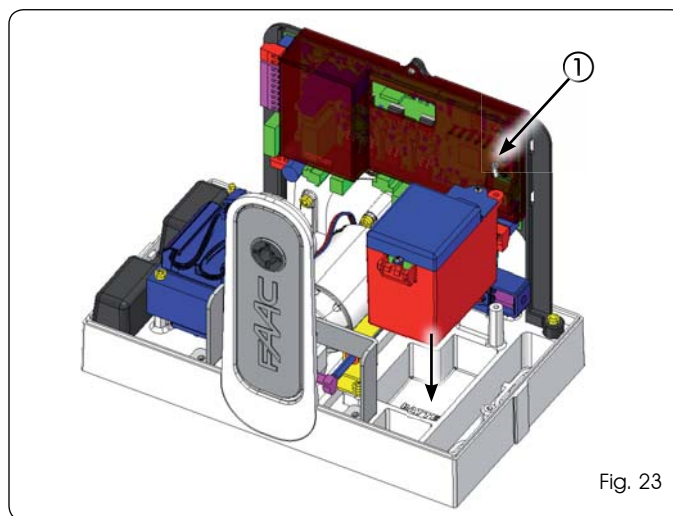

Fig. 23

### 11.2 RADIO MODULE

Install the radio module as shown in Fig. 24.

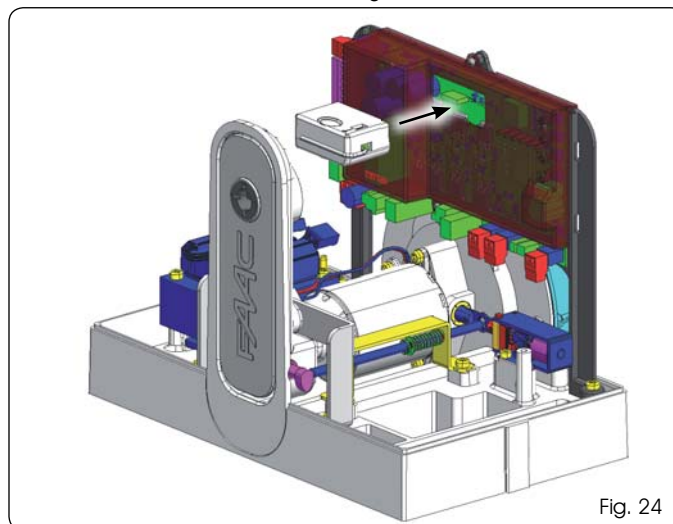

Fig. 24

### 11.3 MOTOR LOCK RELEASE BATTERIES

Install the motor lock release batteries as shown in Fig. 25 and connect to the appropriate connector on the board (see relevant instructions).

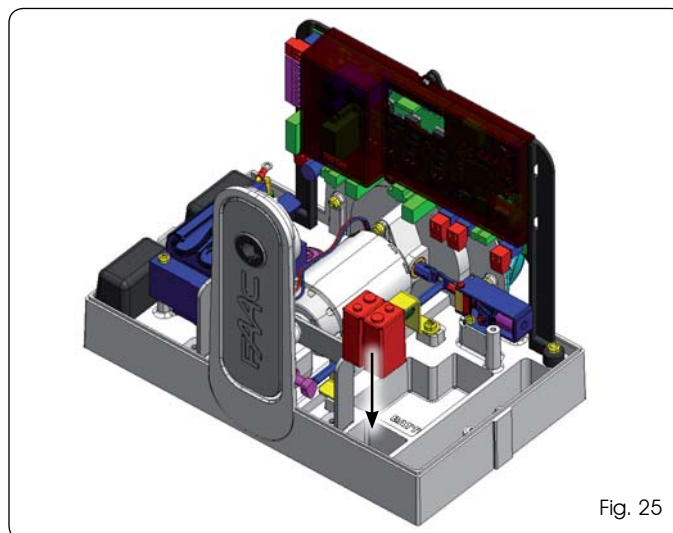

Fig. 25

## C720 USER GUIDE

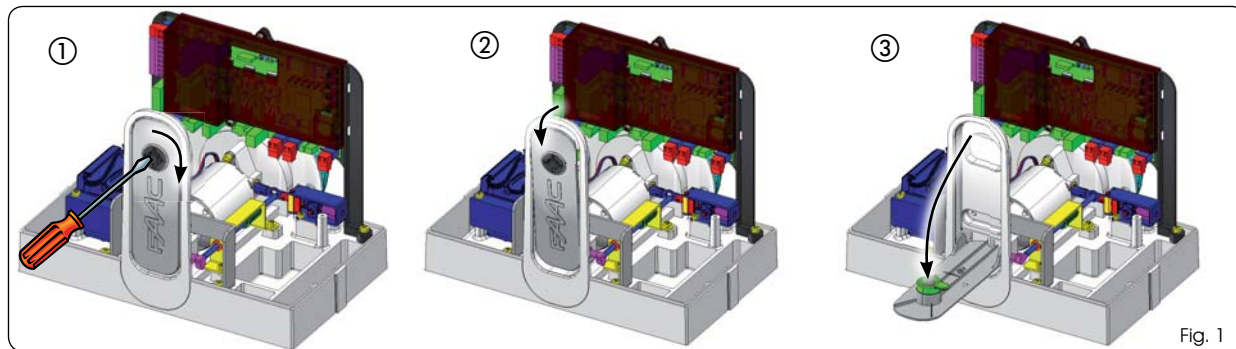

Fig. 1

Read the instructions carefully before using the product and keep for any future needs.

### GENERAL SAFETY RULES

If correctly installed, automated system C720 guarantees a high level of safety. Obeying some simple rules can also prevent accidental problems:

- Do not allow children or adults to stay near the automated system, particularly avoid it while it is operating.
- Keep radiocontrols or other pulse generators away from children, to prevent the automated system from being activated involuntarily.
- Do not allow children to play with the automated system.
- Do not forcibly restrain the gate's movement.
- Prevent branches or shrubs from interfering with gate movement.
- Keep the illuminated signalling systems efficient and very visible.
- Do not attempt to operate the gate by hand until it has been released.
- In the event of malfunction, release the gate to allow access and wait for qualified technical personnel to repair it.
- Once manual operating mode has been set, turn off the power supply to the system before restoring normal operation.
- Do not in any way modify the components of the automated system.
- The user must not attempt any kind of repair or direct action whatever and contact qualified personnel only.
- Ensure the efficiency of the automated device, the safety devices and the earth connection are checked at least every six months by qualified personnel.

### DESCRIPTION

The C720 automated system is ideal for controlling vehicular access areas with medium transit frequency.

The C720 automated system for sliding gates is an electro-mechanical operator transmitting motion to the sliding leaf via a rack or chain pinion appropriately coupled to the gate.

The operation of the sliding gate is managed by an electronic control device housed inside the operator or in a watertight outdoor container.

When the device receives an opening command via a radiocontrol or any other suitable device with the gate closed, it operates the motor until the gate reaches its open position.

If automatic operation has been selected, the gate re-closes by itself after the selected pause time.

If semi-automatic operating mode has been selected, a second pulse must be sent to re-close the gate.

An opening pulse issued during the re-closing stage always causes a reversal of motion.

A stop pulse (if applicable) always stops motion.

The warning light indicates the current gate movement.

For the detailed behaviour of the sliding gate during the various operating modes, consult the installing technician.

The automated systems contain obstacle detection and/or safety devices (photocells, edges) that prevent the gate closing when an obstacle is located in the scanned area.

The system ensures the gate is mechanically locked when the motor is not operating and no lock therefore needs to be installed.

Manual opening is therefore only possible if the appropriate release system is operated.

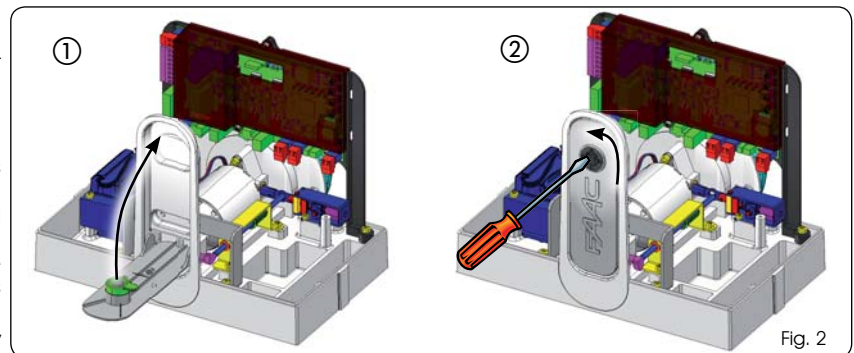

Fig. 2

The gearmotor is equipped with a device with electronic anti-crushing system that offers the necessary safety if the gate should strike an obstacle during its motion by causing it to reverse direction immediately. A handy manual release makes it possible to move the gate in the event of a power cut (if no back-up batteries are installed) or malfunction.

### MANUAL OPERATION

**⚠ During the release/lock manoeuvre, take care to prevent an involuntary pulse from operating the gate.**

Proceed as follows to release the gearmotor:

1. Turn the release clockwise as shown in Fig. 1 re. ①. The release lever will move slightly away from the operator body (Fig. 1 re. ②).
2. Fully lower the release lever to the mechanical stop Fig. 1 re. ③.
3. Carry out the opening or closing manoeuvre manually.

### RESTORING NORMAL OPERATION

Proceed as follows to lock the gearmotor:

1. Fully raise the release lever to the mechanical stop, Fig. 2 re. ①.
2. Turn the release anticlockwise as shown in Fig. 2 re. ②.

**⚠ To maintain the operator intact, avoid pulsing the gate to operate before resetting the release system.**

### MAINTENANCE

It is advisable to check the efficiency of the system at least every 6 months, particularly the efficiency of the safety devices (including the motor thrust force, which must comply with current standards) and of the release devices.

### REPAIRS

Contact an authorised Repair Centre for repairs.

### AVAILABLE ACCESSORIES

Refer to the catalogue for the available accessories.

Le descrizioni e le illustrazioni del presente manuale non sono impegnative. La FAAC si riserva il diritto, lasciando inalterate le caratteristiche essenziali dell'apparecchiatura, di apportare in qualunque momento e senza impegnarsi ad aggiornare la presente pubblicazione, le modifiche che essa ritiene convenienti per miglioramenti tecnici o per qualsiasi altra esigenza di carattere costruttivo o commerciale.

The descriptions and illustrations contained in the present manual are not binding. FAAC reserves the right, whilst leaving the main features of the equipments unaltered, to undertake any modifications it holds necessary for either technical or commercial reasons, at any time and without revising the present publication.

Les descriptions et les illustrations du présent manuel sont fournies à titre indicatif. FAAC se réserve le droit d'apporter à tout moment les modifications qu'elle jugera utiles sur ce produit tout en conservant les caractéristiques essentielles, sans devoir pour autant mettre à jour cette publication.

Die Beschreibungen und Abbildungen in vorliegendem Handbuch sind unverbindlich. FAAC behält sich das Recht vor, ohne die wesentlichen Eigenschaften dieses Gerätes zu verändern und ohne Verbindlichkeiten in Bezug auf die Neufassung der vorliegenden Anleitungen, technisch bzw. konstruktiv/kommerziell bedingte Verbesserungen vorzunehmen.

Las descripciones y las ilustraciones de este manual no comportan compromiso alguno. FAAC se reserva el derecho, dejando inmutadas las características esenciales de los aparatos, de aportar, en cualquier momento y sin comprometerse a poner al día la presente publicación, todas las modificaciones que considere oportunas para el perfeccionamiento técnico o para cualquier otro tipo de exigencia de carácter constructivo o comercial.

De beschrijvingen in deze handleiding zijn niet bindend. FAAC behoudt zich het recht voor op elk willekeurig moment de veranderingen aan te brengen die het bedrijf nuttig acht met het oog op technische verbeteringen of alle mogelijke andere productie- of commerciële eisen, waarbij de fundamentele eigenschappen van de apparaat gehandhaafd blijven, zonder zich daardoor te verplichten deze publicatie bij te werken.



# FAAC

**FAAC S.p.A.**  
Via Benini, 1  
40069 Zola Predosa (BO) - ITALIA  
Tel. 0039.051.61724 - Fax. 0039.051.758518  
[www.faac.it](http://www.faac.it)  
[www.faacgroup.com](http://www.faacgroup.com)

